

# GOVERNMENT OF WEST BENGAL



सत्यमेव जयते

## WATER RESOURCES INVESTIGATION AND DEVELOPMENT DEPARTMENT

### SCHEDULE OF RATES 2018

[Incorporation of GST Act, 2017 & all addenda & corrigenda of  
SOR, 01.10.2016]

Effective from: 18.01.2018

# **GOVERNMENT OF WEST BENGAL**

## **WATER RESOURCES INVESTIGATION AND DEVELOPMENT DEPARTMENT**

### **SCHEDULE OF RATES**

**For Works Under**

**WATER RESOURCES INVESTIGATION AND DEVELOPMENT  
DEPARTMENT**

**Effective From: 18<sup>th</sup> January, 2018**

**2018**

# PREFACE

*In pursuance of Order No. 2779-WI / BP /9M-5/2016 dated: 04.12.2017 of the Principal Secretary to the Government of West Bengal, Department of Water Resources Investigation & Development, this present Schedule of Rates has been prepared.*

*Now, after promulgation of GST from 01.07.2017, it was felt to revise the rates of all items considering only the basic price (i. e. exclusive of GST). GST is to be added later on. **Sample Abstract sheet for preparing DPR given herein after (Annexure 'X')**.*

*For incorporation of GST Act, 2017, the Construction Labour Welfare Cess (1%) which was included within rates of item previously has been extracted from the entire items.*

***This will take effect on & from 18.01.2018***

*All efforts have been taken for keeping this present revision error free. However, effective suggestion for any correction, addition & alteration are always welcome for making it error free.*

*At last, we on behalf of the Schedule Revision Committee would like to convey our sincere thanks to those Engineers Officers who have extended with valuable suggestions and also expect fruitful comments & suggestions from all corners.*

A handwritten signature in black ink, consisting of a stylized 'A' shape with a horizontal line extending to the right, and a smaller signature below it.

## **ANNEXURE 'X'**

ONE SPECIMEN

GENERAL ABSTRACT OF COST

Project Title: CONSTRUCTION OF PROPOSED .....

Sl. No.	Description	Amount (Rs)
1	Cost for Drilling Works	V
2	Cost for Pump House/Civil Works	W
3	Cost for Pipe Line Work, if any	X
4	Cost for Ancillary Work, if any	Y
5	Cost for Electrical Work, if any	Z
6	Sub-total Cost (1+2+3+4+5)	$A=(V+W+X+Y+Z)$
7	GST, as applicable on Sl. No.- 6	B
8	Cost of all works excluding labour welfare cess (6+7)	$C=(A+B)$
9	Labour welfare cess @1% on Sl. No.- 8	D
10	Cost of all works including labour welfare cess (8+9)	$E=(C+D)$

Note: Contingency Charge @ 3% is to be considered on Sl. No. – 8.

*Km*

*A*

# WATER RESOURCES INVESTIGATION & DEVELOPMENT DEPARTMENT

## SCHEDULE OF RATES

[2018]

### INTRODUCTION

1. The Schedule of rates was prepared originally in 1995 as per order communicated vide No. 1803(2) dated 31.01.1992 of Chief Engineer (Agri) and in pursuance of para 185 of P. W. Code and in exercise of powers delegated under Section 16 of Schedule 'B' Part II of the said Code which was in force in the Department of Water Resources Investigation and Development (formerly Department of Agriculture, M. I. Wing). The Director of Personnel & Ex-officio Chief Engineer, W. R. D. D., West Bengal formed a Schedule Committee vide Memo. No. 18651(10)/1(12) dated 20.11.1995 comprising Superintending Engineer (A-I), Kolkata (A-I) Investigation & Planning Circle as Convener Member and Superintending Engineers of (A-I) & (A-M) Circles under W. R. D. D. as Members for Revision of Departmental Schedule of rates. Then the Schedule of rates of some chapters was partially revised and updated in 1998. Subsequently, the schedule of rates was thoroughly revised and updated in 2007 and some partial revision time to time. Now, in the present revision, the existing schedule of rates has been updated with the help of the Schedule Revision Committee and subsequent review and recommendation by the Chief Engineer and approved by Government as per G. O. No.154-WI/BP/9M-5/2016 dated 18-01-2018. Necessary guidance has also been taken from I & W D Schedule of rates, P. W. D. Schedule of rates of various Circles and P & R. D Schedule of rates.

The existing Schedule of Rates of WRI & DD was partially revised with effect from 01.10.2016 vide Memo No. 252(15)/SOR-WRI&DD/ 2016 dated 21.11.2016 of SE (A-I). IP&D Circle, SWID and Convener, Schedule Revision Committee, WRI&DD formed vide No. WRID/3875 dated 14.06.2016 of Secretary, WRI & DD and duly circulated vide No. 483-JS(MI)/16 dated 14.06.2016. Further some rates of Drilling and Laying of Pipe Line etc. have been modified with immediate effect and Rates of Earthwork in excavation for WDS/WHS/Reservoirs/SFMIS etc. also have been modified with immediate effect and circulated by Joint Secretary (MI), WRI&DD vide his No. 1398/WI/BP/9M-5/2016 dated 05th June, 2017.

Now, the present revision of Schedule of rates has been necessitated in view of introduction of GST act, 2017 & consequent revision of PWD Schedule of rates, 2017, with the help of SRC formed vide No. 2779-WI/BP/9M-5/2016 dated 04.12.2017 of Principal Secretary, WRI&DD.

2. Water Resources Development Directorate undertake various type of works viz. Tube wells schemes, River lift irrigation schemes, Surface flow minor irrigation schemes, Diversion schemes, varieties of Civil construction works including carriage etc. An attempt has been made to provide Schedule of rates of all possible items of such works, which are included and associated with M. I. activities or its allied activities undertaking by W.R.D.D. or S.W.I.D. Attempt has also been made to provide schedule of rates for various type of repair and maintenance works normally undertaken by the W. R. I. & D. Department.
3. The present WRI&DD Schedule of Rates is broadly divided into the following categories of work:

- i) Installation of tube wells (H.D.T.W., M.D.T.W., L.D.T.W., S.T.W., Exploratory-cum-Production Well etc.).
- ii) Surface flow minor irrigation / Diversion schemes.
- iii) Pipeline works for River Lift and Tube well irrigation Schemes with R.C.C., A.C., P.V.C. pipes and repair of R.C.C., A.C. & P.V.C. Pipe lines of Tube Wells and R.L.I. Schemes.
- iv) Miscellaneous works :
  - a) Electrical and Mechanical works relating to River Lift and Tube well Irrigation Schemes.
  - b) Repair of Motor / Pump.
  - c) Repair and maintenance of Tube wells including Surging.
  - d) Repair of Steel Burge
  - e) Carriage of different materials.
  - f) Earth work in WDS/WHS/Reservoir/SFMIS
  - g) Sprinkler & Micro Irrigation System

**A. For Building works and related Repair Maintenance works, current schedule rates of P.W.D. to be followed.**

**B. For Sanitary and Plumbing works, current schedule rates of P.W.D.(S&P) to be followed.**

**C. For Electrical works, current schedule rates of Electrical wing of P.W.D. to be followed.**

**D. For Road works, current schedule of Rate of PWD (Roads) to be followed.**

**E. I & W.D Schedule of Rates may also be followed for the items not available in the Schedules as stated above.**

4. The rates provided in the WRI&DD Schedule are the base rates which are inclusive of 10% contractor's profit but excluding 1% cess and relevant Sales Tax without changing the accepted rates of the existing schedule.
5. The primary works of this department is to supply irrigation water from various types of tube wells, river lift irrigation schemes, surface flow minor irrigation schemes, sprinkler irrigation schemes, rain water harvesting schemes and hydrants besides other civil works. The works envisages operation and maintenance of thousand of tube wells and R.L.I. schemes which necessitate procurement of thousand of spare parts, the rates of which have not been incorporated in the Schedule of works, since it varies in the market continuously.
6. Engineer-in-Charge as referred in the Schedule of rates will mean Executive Engineer of the division concerned. The Executive Engineer may authorize his Assistant Engineer and Sub-Assistant/Junior Engineer to represent him in the matter of supervision on his behalf.
7. The tube wells and river lift irrigation schemes are generally installed in cultivable field/on the river embankment located at remote places, away from town. So it involves extra carriage by cart/boat/head load besides initial transport of construction materials by truck. Therefore for construction of pump houses of RLI/Tube wells following extra rate should be allowed over the schedule rates :
 

(i)	HDTW/MDTW	- 3%
(ii)	RLI	- 4%
(iii)	STW/LDTW	- 5%

8. For surface flow minor irrigation scheme and field channel works extra rate of 4% should be allowed over the existing schedule of rates excluding earthwork.
9. The rate of works, involving carriage, in general, covers and includes all cost of any ancillary, construction of temporary roads over field and / or culverts, repairing of existing roads and / or culverts, carrying materials by head load, cart or boat, if not specifically mentioned otherwise in the description of the items of works.
10. This schedule of rates is thoroughly revised and checked to avoid all possible omissions and errors. If, however any omission or error is detected, the same may be brought to the notice of the undersigned specially by our Engineers, for necessary correction and incorporation in future.

Khadya Bhavan, 6<sup>th</sup> Floor, Block-B,  
11A, Mirza Galib Street,  
Kolkata - 700087.



[ Debdatta Datta ]  
Chief Engineer – II, WRDD  
&  
Chairman of Schedule Revision Committee

# WRI&DD Schedule Of Rates 2018

## CONTENTS

	Page
Conversion Table	.....
Table showing discharge through 90 <sup>0</sup> V-Notch	.....
Tabulation of yields from circular orifice meter and Estimation of discharge	.....
Frictional head loss in rigid P.V.C. pipes and R.C.C. Pipes	.....
Dimension of rigid P.V.C. pipes	.....

### CHAPTER - I

#### CIVIL WORKS

General specification, execution and mode of measurements	
1.10 General specification	.....
1.20 Execution	.....
1.30 Mode of measurement	.....
1.40 Consumption of materials	.....

### CHAPTER - II

#### INSTALLATION OF TUBEWELLS

General specification, execution	
2.10 H.D.T.W and M.D.T.W	.....
2.20 L.D.T.W and S.T.W	.....

### CHAPTER - III

#### DIVERSION SCHEME

General specification, execution, materials and mode of Measurements and consumption of materials	
3.10 General specification of materials and execution	.....
3.20 Mode of measurements	.....
3.30 Consumption of materials	.....

### CHAPTER - IV

#### LIFT IRRIGATION SCHEME

Installation, operation and maintenance	.....
---	-------



## CHAPTER - V

### DESIGN OF PIPELINE

5.10	P.V.C. pipeline of R.L.I. Scheme	.....	.....
5.20	P.V.C. pipeline of H.D.T.W.	.....	.....

## CHAPTER - VI

### SCHEDULE OF RATES

#### **1.00 DRILLING OF TUBE WELLS**

1.10	Heavy Duty Tubewell of size 350 mm x 200 mm NB	.....	.....
1.20	Medium Duty Tubewell of size 250 mm x 150 mm N	.....	.....
1.30	Exploratory cum production wells	.....	.....
1.40	Light Duty Tubewell	.....	.....
1.50	Shallow Tubewell	.....	.....
1.60	Performance of Pumping Test	.....	.....
1.70	Piezometric Tube	.....	.....

#### **2.00 LAYING OF PIPELINE**

2.10	Earth work for Pipe line	.....	.....
2.20	Laying of P.V.C. Pipeline for H.D.T.W.,M.D.T.W, and R.L.I Schemes and A.C.P Pipeline for M.D.T.W and Mini RLI Schemes	.....	.....
2.30	Laying inclding of repairing of R.C.C Pipeline in H.D.T.W /R.L.I Scheme	.....	.....
2.40	Repair of P.V.C Pipelines in H.D.T.W/M.D.T.W/ R.L.I Scheme	.....	.....

#### **3.00 INSTALLATION OF CENTRIFUGAL PUMPING SET** .....

#### **4.00 REPAIR OF ELECTRO MOTOR** .....

#### **5.00 INSTALLATION AND WITHDRAWAL OF VT & SUBMERSIBLE PUMP** .....

#### **6.00 SURGING AND MAINTENANCE OF TUBEWELL** .....

#### **7.00 REPAIR OF STEEL BARGE AND OTHER SIMILAR NATURE OF WORKS** .....

<b>8.00</b>	<b>CARRIAGE OF MATERIALS</b>	.....
<b>9.00</b>	<b>MISCELLANEOUS ITEMS</b>	.....
<b>10.00</b>	<b>EARTH WORK FOR WDS/WHS/RESERVOIR/SFMIS etc</b>	.....
<b>11.00</b>	<b>MICRO IRRIGATION SYSTEM (SPRINKLER AND DRIP)</b>	.....

**SKETCHES**

Section of Typical H.D.T.W.	.....	Sketch 1
Section of Typical M.D.T.W.	.....	Sketch 2
Details of Slotting of well screen	.....	Sketch 3
Model command area of R.L.I. Schemes showing buried pipe distribution system	.....	Sketch 4
P.V.C. pipeline closed loop and branching system	.....	Sketch 5
Model H.D.T.W. irrigation command and pipeline (P.V.C)	.....	Sketch 6

## CONVERSION TABLE

### LENGTH

1 inch. (in.) = 2.54 centimetre (cm.) = 25.4 milimetre (mm) 1 foot (ft.) = 30.48 cm. = 0.3048 metre (m) 1 mile = 1.6093 Kilometre (km) 1 Chain (Engineer's)=100 ft.	1 cm. = 0.3937 in. 1 m. = 3.2808 ft. 1 km. = 0.62137 mile 1 Chain (metre) =30 M
--	--

### AREA

1 sq.inch. = 6.4516 sq.cm. 1 sq.ft.(sft.) = 0.0929 sq.m. 1 Acre = 3.025 Bigha = 60.50 Cottah 1 Ha. = 10,000 m <sup>2</sup>	1 sq.cm = 0.1550 sq.inch. 1 sq.m = 10.76 sft. 1Acre = 4048.32sq.m. = 43560sq.m. 1 Sq.Km. = 100 Ha
--	---

### VOLUME

1 cu.ft.(cft.) = 0.028317 cu.m 1 gal. (imp). = 4.54596 litres 1 Acre. in.= 3630 cft. 1 Imp.Gal.= 1.2 U.S. Gal.	1 cu.m = 35.315 cft. 1 litre = 0.212976 gal. 1 Ha.m = 10,000 m <sup>3</sup> = 8.10 Acr.Ft.
---	---

### WEIGHT

1 lb. = 0.4536 kg. 1 ton = 1.01605 tonne	1 kg. = 2.2046 lb. 1 tonne = 1000 kg = 0.98421 ton.
---	---

### DISCHARGE

1 m <sup>3</sup> /hr = 0.277 lit./sec. = 220.26 Imp. Gal/hr. = 0.0612 Imp. Gal/sec = 0.07344 U.S. Gal./sec	1 cu.mec = 35.315 cu.sec. = 1000 litre/sec. 1 cu.sec. = 2,446 Gal(Imp)/hr. = 101.9406 cum/hr = 28.3168 Lps
1 litre/sec. = 3.60 m <sup>3</sup> /hr. 1 litre/sec. = 791.88 imp Gal/Hr.	

### PRESSURE

1 lb/sq.in. = 0.0703 BAR	1lb/sft. = 4.88 kg/sq.m.
--------------------------	--------------------------

### DENSITY

1 lb/cft. = 16.0185 Kg/CuM	
----------------------------	--

DISCHARGE THROUGH 90°V-NOTCH		
Height of Water Over V-Notch (cm)	Litres	Per hour
	Per Sec.	
Cubic Metre per	DISCHARGE	
Hour	Per hour	Per hour
4.0	0.45	357.00
4.5	0.60	476.00
5.0	0.80	635.00
5.5	1.00	793.00
6.0	1.2	952.00
6.5	1.50	1190.00
7.0	1.80	1428.00
7.5	2.20	1745.00
8.0	2.50	1983.00
8.5	2.80	2221.00
9.0	3.40	2697.00
9.5	3.90	3094.00
10.0	4.50	3570.00
10.5	5.10	4046.00
11.0	5.70	4522.00
11.5	6.30	4998.00
12.0	7.10	5633.00
12.5	7.80	6188.00
13.0	8.60	6823.00
13.5	9.50	7537.00
14.0	10.50	8330.00
14.5	11.30	8965.00
15.0	12.30	9758.00
15.5	13.30	10551.00
16.0	14.50	11503.00

DISCHARGE			
Height of Water Over V-Notch (cm)	Litres Per Sec.	Cubic Metre per Hour	Imp. Gall Per hour

16.5	15.60	56.16	12376.00
17.0	16.70	60.12	13249.00
17.5	18.30	65.88	14518.00
18.0	19.40	69.84	15391.00
18.5	21.70	78.12	17215.00
19.0	22.30	80.28	17691.00
19.5	23.50	84.60	18643.00
20.0	25.50	91.80	20230.00
20.5	27.00	97.20	21420.00
21.0	28.30	101.88	22451.00
21.5	30.30	109.08	24038.00
22.0	31.00	111.60	24593.00
22.5	34.00	122.40	26973.00
23.0	35.70	128.52	28322.00
23.5	38.20	137.52	30305.00
24.0	40.00	144.00	31733.00
24.5	42.70	153.70	33874.00
25.0	44.50	160.20	35303.00
25.5	46.70	168.12	37049.00
26.0	48.80	175.68	38715.00
26.5	51.00	183.60	40460.00
27.0	53.80	193.61	42681.00
27.5	56.30	202.68	44664.00
28.0	58.70	211.32	46568.00
28.5	61.50	221.40	48790.00
29.0	64.50	232.20	51170.00
29.5	66.80	240.48	52994.00
30.0	69.40	249.84	55057.00

Head of Water In Tube above Centre of Orifice.	Inches	G.P.M.	G.P.M.	G.P.M.	G.P.M.
	6	102	155	300	380
	7	110	168	325	410
	8	118	180	350	440
	9	126	190	370	465
	10	132	200	390	490
	12	145	220	425	540
	14	156	238	460	580
	16	168	253	490	620
	18	178	268	520	660
	20	188	283	550	695
	22	198	298	575	725
	25	210	318	610	780
	30	230	350	670	850
	35	250	375	725	920
	40	265	400	780	980
	45	280	425	820	1040
	50	300	450	870	1100
	60	325	490	950	1200

**TABLE OF YIELDS FROM CIRCULAR ORIFICE METER  
YIELD IN U.S. GALLON PER MINUTE**

**Estimation of discharge from Shallow / Light Duty Tubewell**

Q [discharge in (GPM)] =  $5.6 D^2 \sqrt{H}$  (U.S. Gallon)

D = Diameter of pipe in inches.

H = Vertical height of Jet in Inches

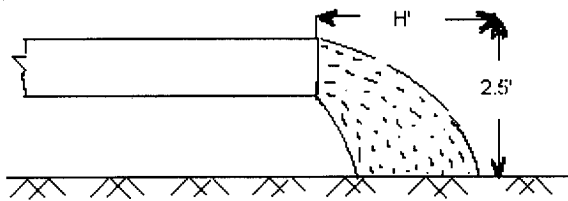

Q [discharge in G.P.M.] =  $\frac{\pi D^2}{4} \times R$  (U.S. Gallon)

D = Diameter of pipe in inches.

R = Horizontal distance of jet from discharge pipe placed 12" above G.L.





DIMENSION OF RIGID P.V.C. PIPES

Sl No.	Out Side Diameter (mm)	Pressure Rating (Kg / cm <sup>2</sup> )	Weight Per Metre (Kg / M)	Wall Thickness (mm)	Inside Diameter (mm)
1.	90	2.5	0.585	1.5	87.0
2.	110	2.5	1.859	1.8	106.4
3.	140	2.5	1.336	2.20	135.6
4.	140	4	2.131	3.5	133.0
5.	160	2.5	1.769	2.55	154.9
6.	160	4	2.783	4.00	152.0
7.	200	2.5	2.732	3.15	198.7
8.	200	4	4.256	4.95	190.1
9.	225	2.5	3.513	3.6	217.8
10.	225	4	5.480	5.6	213.8
11.	250	2.5	4.230	3.90	242.2
12.	250	4	6.636	6.1	237.8
13.	315	2.5	6.764	4.9	305.2
14.	315	4	10.553	7.70	299.6

**Chapter-I**  
**CIVIL WORKS**

**General Specification, Execution & Mode of Measurements**

**1.10 General Specification**

**General :** All materials to be used in works shall be of approved quality bearing ISI certificate mark. When materials with such certificate marks are not available, the same are to be get approved by the Engineer-in-charge before use.

**A-1 BRICK :** All bricks shall be of approved quality of standard specifications, made of good brick earth, uniform deep red, cherry or copper colour, thoroughly burnt in kiln (machine made) without being vitrified, regular in shape and size, sound, hard, homogeneous in texture, true to shape and of standard dimension and shall be free from cracks, chips flaws, stones or humps of any kind and shall not show appreciable signs of efflorescence either dry or subsequent to soaking in water. The size of bricks shall be  $9\frac{3}{4}$  "  $\times$   $4\frac{3}{4}$  "  $\times$   $2\frac{3}{4}$  " (conventional), 190  $\times$  90  $\times$  90 mm (modular). The Bricks shall emit a clear ringing sound on being struck and have minimum crushing strength of 105 kg./sq.cm. All the bricks which absorb water more than 20% of their own dry weight after 24 hours immersion in cold water shall be rejected.

**A-2 COARSE AGGREGATE :**

- a) (i) Stone chips of stone ballast for cement concrete work (plain or reinforced shall be hard, of uniform and fine texture, free from faults or plane of weakness and free from weathered faces. The ballast or chip must be free from, loamy clay or any surface coating free from organic matter or other impurities and screened free of dust. Stone of black and hard variety as is generally available from quarries in Pakur areas will be normally used. Stone aggregates from other sources may also be used provided the same is found suitable in the opinion of the Engineer-in-charge. The ballasts or chips shall be obtained by breaking from large blocks and must be more or less cubical in shape. Stone chips and Ballast should be graded in a way to give maximum density (i.e. minimum void.).
- (ii) Gravel, for use as coarse aggregates in cement concrete work, must be hard, absolutely free from surface coating and on being broken the fractured surface must indicate a uniform and fine texture free from laminations of planes of weakness. It should be thoroughly washed and freed of all foreign materials.
- (iii) Jhama chips for cement concrete work shall be obtained by breaking good quality Jhama bats and must not be spongy or with any coating of materials. The chips shall be of more or less cubical shape.
- (iv) All coarse aggregate for concrete work must be well graded. These shall be screened for removal of dust and if so necessary in the opinion of the Engineer-in-Charge shall be washed at the cost and expense of the contractor.

**A-3 COARSE AGGREGATE FOR LIME CONCRETE WORKS :**

- (i) Brick aggregate for lime concrete in foundation or flooring shall consist of approved, clean hard and well burnt jhama khoa. The khoa must be graded and unless otherwise specified shall pass through 32 mm. ring.
- (ii) Brick aggregate for lime terracing on roof shall consist of khoa broken from 1<sup>st</sup> class brick bats and unless otherwise specified shall pass through 25 mm. ring and be suitably graded. No jhama khoa should be used in lime terracing work.

**A-4 SAND :** All sand shall be clean, sharp and free from clay loam organic or any other foreign matter and shall be obtained from approved sources. The contractor shall get the samples of sand to be used in different kinds of work approved by the Engineer-in-charge before using the same in work. Sand which in the opinion of the Engineer-in-charge or his representative, is dirty, must be washed to his satisfaction at the cost and expense of the Contractor.

- (i) Sand for all cement concrete works should be coarse (heavier). The sand shall pass through a mess of 5 mm. Square measured clear. Sand shall not be used for concrete work if it contains more than 10 per cent of fine grains passing a 76 mesh sieve as used for cement test nor should the fineness modulus be less than 2:00 unless specific permission is obtained from Engineer-in-charge.
- (ii) Medium coarse sand should be used for cement mortar for masonry, plaster etc.
- (iii) Fine sand should be used for building plinth-filling and the like.
- (iv) In Malda District only BANSLOI sand should be used in all types of cement works. In Nadia and Murshidabad Districts, coarse sand from SAINTHIA only should be used in structural concrete works.

**A-5 SURKI :** Surki shall be made from well burnt 1<sup>st</sup> class bats, ground to pass through a mesh 16 mm. each way and shall be perfectly clean and free from any foreign matter.

**A-6 LIME :** All lime shall be freshly burnt and slaked and screened before use.

- (i) Lime for works including roof terracing shall be Bisra, Satna or other approved stone lime. The specification covers lime as used in construction of building and other structures as described below (refer P.W.D. standard specifications, chapter II and I.S. : 712 – 1973).
  - a) Quick-lime shall mean a calcined material, the major part of which is calcium oxide in natural association with a relatively small amount of magnesium oxide and capable of slaking with water.
  - b) Fat lime shall mean the lime which has high calcium oxide content (between 95 and 100 percent) and is dependent for setting and hardening on the absorption of carbon dioxide from the atmosphere. This is defined as class-C in I.S. : 712-1973 which is used for finishing coat in plastering, white washing etc. and with addition of pozzolanic materials (surki) for masonry mortar.
  - c) Hydraulic lime shall mean the lime which contains small quantities of silica and alumina and / or iron oxide which are in chemical combination with some of the calcium oxide content, giving a putty or mortar that has the property of setting and hardening under water.

d) Hydrated lime shall mean a dry powder resulting from treatment of quick-lime with water enough to satisfy its chemical affinity for water under the conditions of hydration.

- A-7 CEMENT :** No cement excepting either those supplying by the Deptt. or approved by the Engineer-in-charge shall be used in work or brought to the site by the Contractor. Cement bags must be stored in a water tight shed as approved by the Engineer-in-charge. Any cement damaged by water or otherwise detected must be removed from site immediately.
- A-8 STEEL :** All steel shall be free from oil and loose rust. Any scale or loose rust shall be removed. MS / Tor Steel Rods of various dias : and categories for reinforced concrete works etc. may be issued in available stock length by the Deptt. at an issue rate. The contractor must accept the actual weight as calculated on tolerance allowed for rolling or on theoretical weight on running metre basis allowed for a particular section of the bar as the case may be depending on the issue rate fixed. All straightening of rods and final straightening of coils already straightened initially must be included in the rate for reinforcement. In case of nonavailability in existing stock, the contractor will procure steel of tested quality and test certificate to that effect must be furnished to the Engineer-in-charge for approval before execution of any work.
- A-9 TIMBER :** All timber shall be of best quality well-seasoned and/or well-treated for preservation and protection against decay etc. It shall be uniform in substance, straight in fiber free from large or dead knots, sap, flaws, sun-cracks, shakes or blemishes of any kind. Any insect damage or splits across the grain shall not be permissible. The colour of the timber shall be uniform throughout, firm and shining with a silky luster when planed and shall not emit dull sound when struck.
- A-10 GLASS :** All glasses shall be of specified type, colour visibility and sound and shall be free from cracks, flaws, spick bubbles and blemishes and shall not weigh less than 7.4 kg./sq.m. unless otherwise specified.
- A-11 TIMBER DOOR, WINDOWS ETC. & THEIR FITTINGS :**
- (i) Door and Window work shall be carried out as per detailed drawings or as directed by the Engineer-in-Charge. Specified timber shall be used, and it shall be sawn in the direction of the grains and be straight and square.
  - (ii) Fittings shall be of iron, brass, aluminium or as specified. These shall be well made, reasonably smooth and free from sharp edges, corners, flaws and other defects. Screw holes shall be counter sunk to suit the head of specified wood screws. Iron fittings shall be finished bright or black enameled or copper oxidized. Brass fitting shall be finished bright (brass), oxidized, or chromium plated (Electroplated) and aluminium fittings shall be finished bright or anodized, or as specified. Fittings shall be got approved by the Engineer-in-Charge before fixing. In case of renewal works, the new fitting shall, as far as possible, match with the existing ones. **Screws shall be driven home with screw driver and not hammered in.**

## 1.20 EXECUTION

**GENERAL :** All works shall be carried out in proper work manlike manner. Items of works not covered by the following, shall be carried out as per best practice according to the directions of the Engineer-in-charge and to his satisfaction. Unless otherwise specified in this section or in the description of item, the cost of all stages of works mentioned hereunder shall be deemed to have been included in the rates of items provided in the schedule.

### B-1(a) Excavation of Foundation and Filling up Trenches :

- i) Foundation when excavated to the level shown in the drawing will be shown to the Engineer-in-Charge and if on account of bad ground or for any reason whatsoever he decides to go deeper with the foundation, the contractor shall excavate further to the depths required by the Engineer-in-Charge. In no case shall the foundation soling or concrete be laid prior to receiving orders to that effect from the Engineer-in-Charge or his authorized representative.
- ii) Excavation shall include throwing the excavated earth at least one metre or half the depth of excavation, whichever is more, clear of the edge.
- iii) The excavated areas around the foundation of structures are to be filled up properly to the required levels with earth obtained from excavation or other materials as directed, well rammed with water and consolidated in layers not exceeding 150 mm. at a time. The quantity for this item of work will be measured on the basis of quantity of excavation paid for less the volume occupied by the structure in foundation.

### B-2 LIME CONCRETE AND TERRACING :

Lime concrete in foundation or in the flooring shall be prepared by mixing graded jhama khoa with wet ground lime mortar, as specified by the Engineer-in-charge, Boxes of suitable size say 35 × 25 cm. And 40 cm. Deep shall be used for measuring the material. While measuring the aggregate, shaking, ramming or hammering shall not be allowed.

The mixing shall be done by hand or mechanical mixer when so specified.

Hand mixing shall be done on clean and water-tight masonry platform of sufficient size to provide ample mixing area. Brick aggregate shall be well soaked with water for a minimum period of 2 hours. The specified wet lime mortar shall be laid on the top of the aggregate. The whole shall then be turned over and above with addition of necessary quantity of water, till a uniform mix of required consistency is obtained. The consistency of concrete shall be such that mortar shall not tend to separate from the coarse aggregate.

Lime concrete shall be laid (and not thrown) in layers while quite fresh. Each layer shall be thoroughly rammed and consolidated before the successive layer is placed. Consolidated thickness of each layer shall not exceed 15 cm. Joints where necessary shall be staggered in different layers. Ramming shall be done by heavy iron rammers 4.5 to 5.5 kg. The area of the rammer shall not be more than 300 square cm. and it shall be continued till a skin of mortar covers the surface completely.

Concrete laid on the particular day shall be consolidated thoroughly on the same day before the work is stopped. Ramming on the following day shall not be done.

After the concrete has begun to harden, i.e., about 24 hours after its laying the curing shall be done by keeping the concrete damp with moist gunny bags, sand or any other material approved by the Engineer-in-charge for a minimum period of 7 days; till then, masonry and flooring work over the foundation or base concrete shall not be started.

### **SPECIFICATION OF LIME TERRACING**

**a) Materials :** (i) Coarse aggregate shall be well burnt first class brick ballast of uniform deep cherry red or copper colour. It shall be free from dust, dirt or other vegetable matters and shall pass through 25 mm (1") dia. ring but retained on 6 mm (¼") square mesh screen. It shall be well graded. (ii) Fine aggregate shall be of Surki grounded from new first class bricks and shall pass through a screen 5 meshes per sq. cm. Surki shall be of uniform colour, free from dirt, vegetable or other foreign matters. (iii) Lime shall be fresh burnt stone lime and shall be free from ash, unburnt stone particles or other foreign matters. Lime shall be screened at site of work through a sieve of 3 meshes per Sq. cm. Beside these all the materials including water shall be of standard specifications.

**b) Mixing :** The mixing shall be done on a clean solid platform. Brick aggregate shall be well soaked with clean water not less than 3 hours before mixing and it shall be stacked evenly on the platform. Lime, Surki and brick aggregates shall be mixed in the proportion 2 : 2 : 7 or as specified. Lime and Surki in the specified quantities shall at first be mixed dry till of uniform colour and it shall be spread over the stacked ballast. The materials shall then be turned over once without adding water and then at least further three times gradually adding water and molasses to give uniform concrete. During the operation of mixing-khunji water is to be sprinkled in damp condition to remove all traces of unslaked lime.

**c) Laying :** The R.C. roof slab over which lime terracing is to be laid shall be at least 28 days' old. The surface of the R.C. shall be cleaned and shall be moistened by sprinkling clear water before laying concrete. Concrete shall then be laid (not thrown) on the roof slab in a single layer about 20% thicker than specified for consolidation with slope (minimum 1 : 60) towards gutter and outlets.

**(d) Consolidation :** The concrete shall then be thoroughly consolidated by beating with wooden mallets (thapies) weighing about 1 kg. slowly and gradually to the specified thickness 10 cm. to 13 cm. (4" to 5") generally. During ramming the surface shall be tested and kept perfectly true and even by means of a towel, straight, edge and spirit level. The beating shall be for at least seven days systematic by lengthwise movement of two rows of labourers (3 nos. beaters per 100 sq.ft.) shall be sited close to each other in a row and shall keep on moving backwards and forwards. While beating of concrete is going on, the surface of the concrete shall be frequently sprinkled with lime water and a mixture of molasses, catechu and methi seeds for water proofing. Methi and molasses solution in lime water are to be added to the concrete while mixing and ramming. For 100 cum. Brick aggregate 35.34 kg. of molasses and 1.77 kg. of methi water to be added at the time of mixing and 17.67 kg. of molasses and 0.89 kg. of methi water are to be added with lime water for sprinkling during ramming. Special care must be taken not to allow the concrete to dry before its thorough consolidation. The beating shall be done in the manner with wooden mallets for at least a week till the roof emits a ringing sound.

**(e) Finishing :** The surface shall be softened by sprinkling pure water and the mortar which is brought to the surface by beating shall then be rendered smooth

and finished off with lime rubbing and afterwards with oil with the face of a trowel. On no account plastering shall be used on the surface but lime putty prepared from lime and surki (1 : 1) may be used if the floated mortar is found insufficient to fill up all the surface pores. The surface shall then be covered with straw kept wet for at least 4 (four) weeks. For drainage of the roof, openings of 4" (10 cm.) bore pipe for 600 sq. ft. of the area in dry regions and 450 sq. ft. in heavy rainfall regions, must be provided.

Ghoondies shall be provided at junctions with parapet etc. and the mouths of rain water pipes shall be properly finished as per direction.

### **B-3. CEMENT CONCRETE WORKS (PLAIN OR REINFORCED) :**

i) Shuttering and staging : Wherever necessary, shuttering and staging must be provided. Unless otherwise stated, no payment will be made for such shuttering or staging and the cost thereof will be deemed to have been covered by the rate for relevant finished item of work. Where payment for shuttering has been specified, the rate shall be deemed to cover the cost of the necessary staging as well. Payment, if any, for shuttering will be on the basis of surface area of shuttering in actual contact with concrete.

ii) Shuttering may be of approved dressed timber true to line not less than 2.5 cm. thick., Surface to be in contact with concrete are to be planed smooth except where otherwise stated. As an alternative, sufficiently rigid steel shuttering may be used for which same rate of timber shuttering shall be allowed. In every case, joints of the shuttering are to be such as to prevent the loss of liquid from the concrete. In timber shuttering the joints shall therefore be either tongued and grooved or the joints must be perfectly closed and lined with craft paper or other types of approved materials. In case of steel shuttering also, the joints are to be similarly lined.

All shuttering and framing must adequately be stayed and braced to the satisfaction of the Engineer-in-charge for properly supporting the concrete during the period of hardening. It shall be so constructed that it may be removed without shock or vibration to the concrete.

iii) Before the concrete is placed, the shuttering shall, if considered necessary, be coated with an approved preparation for preventing the adhesion of the concrete of the finished concrete is not stained. Care shall also be taken that such approved preparation shall be kept out of contact with reinforcement.

In no circumstances, shall forms be struck until the concrete reaches a strength of at least twice the stress of which the concrete may be subjected at the time of striking.

Interior of all moulds and boxes must be thoroughly washed out with a hose pipe or otherwise so as to be perfectly cleaned and free from all extraneous matter previous to the deposition of concrete.

All form-work shall be removed without shock or vibration. Before the form work is stripped, the concrete surface shall be exposed where necessary in order to

ascertain that the concrete has hardened sufficiently. In normal weather and with ordinary cement vertical or side shuttering may be removed after three days and the bottom shuttering of horizontal members after fourteen days in case of slabs and twenty-one days in case of beam and cantilevers etc. from the date of placing the last portion of the concrete in the structure. The above period are the minimum and may be extended if found necessary. Before stripping the shuttering of structural members, the contractor shall take previous permission of the Engineer-in-charge or his representative.

iv) Protection and curing : The contractor shall adequately protect freshly laid concrete, about 1 to 2 hours after its laying, from too rapid drying due to sunshine, drying winds etc. and also from running of surface water and shocks. After 24 hours of laying of concrete, the surface shall be cured by flooding with water of minimum 25 mm depth or by covering with wet absorbent materials. The curing shall be done for a minimum period of 10 days. Over foundation concrete masonry work may be started after 48 hours, but curing shall be continued for 10 days.

**TEST SPECIFICATION** - The test specimens shall be made from each sample for testing at 28 days. Additional cubes may be required for various purposes such as to determine the strength of concrete at 7 days or at the time of striking the form work, or to determine the duration of curing, or to check the testing error. Additional cubes may also be required for testing cubes cured by accelerated methods as described in IS : 9013-1978. The specimen shall be tested as described in IS : 516-1959.

**TEST STRENGTH OF SAMPLE** - The test strength of the samples shall be the average of the strength of three specimens. The individual variation should not be more than  $\pm$  15 percent of the average.

Concrete shall be handled from the place of mixing to the place of final deposit as rapidly as practicable by methods which will prevent the segregation or loss of the ingredients. It shall be deposited as nearly as practicable in the final position to avoid re-handling or flowing. Unless specially permitted by the Engineer-in-Charge, concrete shall not be dropped freely from a height of more than 2 metres.

Before placing the concrete, the moulds shall be cleaned of shavings, pieces of wood or other rubbish. When placing the concrete the finer materials must be carefully worked against the moulds so the faces of concrete shall be left perfectly smooth and free from honey-combing upon withdrawal of the moulds. Any defect in this respect must be dealt with by the contractor as directed by the Engineer-in-Charge without any extra charges thereof.

Depositing concrete under water shall not be allowed without specific permission from the Engineer-in-Charge. The method of concreting to be adopted in such cases shall have to be previously approved by him.

During placing and also immediately after deposition, the concrete shall be thoroughly compacted by ramming, spearing etc. until it has been made to penetrate and fill all the spaces between and around the steel rods, around embedded fixtures, and into the corners of formwork in such a manner as to ensure a solid mass entirely free from voids. If so directed by the Engineer-in-Charge, in addition to usual ramming, spearing etc. sufficient number and suitable type of vibrators may have to be used on important jobs to



enable working with homogeneity. It is imperative that the work should be done quickly as well as efficiently and adequate number of hands must be employed to ensure this.

Concrete shall be placed and compacted in its final position before setting has commenced and shall not subsequently be disturbed.

Concreting shall be carried out continuously up to construction joints, the position and arrangement of which shall be predetermined by the Engineer-in-Charge or his representative. Any rest, pauses, such as for meal, shall also be subject to his approval. All concreting work should be so programmed as not to necessitate work at night. If for any reason this becomes imperative, the contractor shall obtain previous permission of the Engineer-in-Charge or his representative and make proper lighting arrangement to his satisfaction.

### 1.30 MODE OF MEASUREMENTS

**GENERAL :-** Unless specifically mentioned otherwise the following modes of measurements shall be adopted. In general the mode of measurements of all Civil Engineering Works shall be guided by ISI code no. IS: 1200-1964 (revised) for Indian Standard Method of measurement of Building works.

#### C-1 BRICK WALLS :-

- a) The thickness of brick wall made with one brick laid on edge with the long side parallel to the length of the wall shall be measured as 7.5 cm.

Similarly, a wall made with one brick laid flat (with the long side parallel to the length of the wall) shall be measured as 12.5 cm, one brick thick walls (with the length of brick parallel to the thickness of the wall) shall be measured as 25 cm. One and half brick walls (i.e. one along the length and one brick along the width) shall be measured as 37.5 cm., two brick walls measured as 50 cm and so on. The width of lintels etc. covering the thickness of brick walls shall also be measured as equal to the corresponding wall thickness.

- b) Net measurement of wall will be taken after deduction of all opening etc. This applies to 12.5 cm thick and 7.5 cm. thick wall also.

Brick work generally shall be measured in cubic metres, walls of half brick thickness or less shall be measured separately in square metres stating the thickness. No additions or deductions shall be made on any account for:-

- i) Ends of dissimilar materials (that is, joists, beams, lintels, posts, girders, rafters, purlins, trusses, corbels, steps etc.) up to 500 cm<sup>2</sup> in section.
- ii) Openings up to 0.1 m<sup>2</sup> in section : and
- iii) Wall plates and bed plates and bearing of slabs CHAJJAS and the like, where thickness does not exceed 10 cm. and the bearing does not extend over the full thickness of the wall. This applies to 12.5 cm. thick and 7.5 cm. thick wall also.

- c) Parapets (up to 1.07 m. height) will be measured along with the brickwork of the floor just below the roof and will be paid for at the same rate.
- d) No extra will be paid for curved or chamfered work even though it may necessitate cutting of bricks. For small curves or chamfers the Engineer-in-charge may at his direction allow measurements on the square (i.e. without deduction for the quantity for forming the small curve or chamfer).

**N.B.** — All metric size bricks are available, detailed measurement maybe taken, until further orders in FPS system and the quantity covered in metric unit before application of rate.

### **C-2 CONCRETE:-**

All measurements for finished work shall be taken to the nearest centimeter except than that of thickness of slabs, partitions etc, and sectional dimensions in case of posts, columns, beams and the like shall be taken to the nearest half centimeter.

- a) In case of plain concrete no deduction shall be made for:
  - i) Ends of dissimilar materials (for example, beams posts, girders, rafters purling, trusses, corbels, steps etc.) up to 500 cm<sup>2</sup> in sections; and
  - ii) Openings up to 0.1 m<sup>2</sup> (in calculating area of opening up to 0.1 m<sup>2</sup>) the size of opening includes the thickness of any separate lintels or sills. No extra labour for forming such openings or voids shall be measured.
- b) In case of concrete cast in site in the form of solid articles (reinforced or otherwise) no deduction shall be made for:
  - i) The volume occupied by reinforcement :
  - ii) The volume occupied by water pipes, conduits etc, not exceeding 25 cm<sup>2</sup> each in cross sectional area :
  - iii) Small voids, when each of these do not exceed 40 cm<sup>2</sup> in section :
  - iv) Joints of any kind (plain riveted, locking tongued and grooved etc.).
  - v) Small, linear labours (including moulding chamfers splays rounded or eave angles, beads, grooves, and etc.) up to 10 cm width or 15 cm. in girth.

### **C-3 REINFORCEMENT :-**

The measurement will be on the basis of calculated weight of reinforcements only (i.e. without considering the weight of tying wires) actually consumed in the finished work as per drawing and design or as that shown in the drawing (but has been allowed to be used) the length will be taken on the length shown in the drawing Hooks and laps, as per standard practice, will be measured and paid for.

**C-4 PLASTER :-**

For measurement of plaster (exterior or interior) deduction is to be made for door, window or openings of similar dimensions and allowance is to be made for jambs, sills and soffits payment will be made on the basis of surface measurement of wall deducting one-third the measurement of such openings and without any separate measurement for jambs sill and soffits. In case of large openings above 3 sqm. Each, however, as in the case of verandahs with columns payment will be made on actual measurement. Ceilings shall be measured between the walls or partitions and the dimensions before plastering shall be taken. The measurements of wall plastering shall be taken between the walls or partition. (the dimensions before plastering shall be taken) for the length and from the top of floor or skirting to the ceiling for the height.

**C-5** For Cement paint works such as snowcem or similar approved brand, oil bound or dry distemper, plastic emulsion etc) to be applied internally or externally or to concrete jally etc. the payment will be made on the basis of actual measurement of surface area for the plaster works having openings, (vide C-4).

**C-6 WHITE WASHING, COLOUR WASHING, CEMENT OR CHALK WASHING:-**

Payment of all work falling under his head shall be made on the basis of surface measurements in square metres, without any separate measurements for jambs, sills and soffits of such opening.

**C-7 PAINTING:-**

- a) Measurement for painting work in doors and windows grills gratings collapsible gates corrugated roofing etc. shall be on the following basis. In all such cases the 'Area' shall be measured flat (and not girthed). For doors and windows, no separate payment shall be made for the frames (chowkats) : the 'Area' in such cases represents the area of the finished wall openings covered by the frames (including exposed surface of the frames). Edges chocks, cleats etc. shall be deemed to be included in measurement. For grills, grating etc. the 'Area' represents the area of the opening covered by the outer frames.
- b) The 'Area' measured as above shall be multiplied by the factor given below and the work of painting shall be paid on the quantities thus arrived at:

Name of surface painted	Multiplying factor for painting one side only	Multiplying factor for painting both sides only.
i) Timber door, windows etc.		
Fully glazed (or with glass substitute).	0.80	1.60
Fully panelled of flush or battened.	1.30	2.60
Fully Venetian or fixed louvered	1.80	3.60
Two third panelled one third glazed	1.14	2.28
Half panelled half glazed	1.00	2.00
One third panelled two third glazed	0.75	1.50
One third panelled two third Venetian (or fixed louvered)	1.33	2.66
Half panelled half Venetian (or fixed – louvered)	1.55	3.10
Netted (without painting to the net)	0.25	0.50
Netted (with painting to the net as well)	0.63	1.25
Corrugated (i.e. with leaves of GI Sheets)	1.25	2.50
ii) Corrugated iron sheet roof or wall	1.14	2.28
iii) Corrugated asbestos sheet or wall	1.20	2.40
iv) Trafford asbestos sheet roof or wall	1.10	2.20
v) Heavy type grating or grated doors (as in jails etc.)	—	1.50
vi) Collapsible gate (all over)	—	1.50
vii) Steel windows (full glazed)	0.50	1.00
viii) Ledged and battened or ledged, battened and braced	1.13	2.25
One third glazed two third Venetians (or fixed louvered)	1.47	2.94
Two third glazed one third Venetian (or fixed louvered)	1.13	2.25
ix) Weather Boarding (supporting frame shall not be measured separately)	1.13	2.25
xi) Trellis (or JAFFRI) work one way or two way (over all members without deducting the open spaces and including the supporting members)	—	2.00
xii) Grills, gratings and railing (cast iron or wooden) guard bars, balustrades (supporting frame work shall not be measured separately)	—	1.00

Name of surface painted	Multiplying factor for painting one side only	Multiplying factor for painting both sides only.
xiii) Steel rolling shutters including top casing (Jambgurdes, bottom rails and locking arrangement etc.) shall be deemed to be included in the item.	1.10	2.20
xiv) Curved or enriched work	2.00	4.00
xv) Gates and open Palisade fencing including standards, braces, rails, stays etc. (for painting all over)	—	1.00
xvi) Partly panelled and partly glazed or glazed steel doors	0.80	1.60
xvii) Plain sheet steel doors and windows	1.10	2.20
xviii) Wood shingle roofing	1.10	2.20
xix) Boarding with cover fillets and match boarding	1.05	2.10

**Notes:-** The height shall be taken from the bottom of the lowest rails, if the palisades do not go below it (or from the lower end of palisades, if they project below the lowest rail up to the top of palisades, but not up to the top of standards, if they are higher than the palisades.)

#### **C-8 GLAZING;-**

All glazing shall be measured in square metres. Each pane of glass shall be measured to the nearest 0.5 cm both width and height. Irregular or circular panes shall be measured as the smallest rectangular area from which the irregular or circular pane can be cut. Irregular panes shall be measured separately, and described as irregular shapes measured square.

#### **C-9 BATS, SAND, SURKI, LIME, COAL, CARRIED EARTH ETC.**

- a) Unless specifically mentioned otherwise in the description of the item itself, measurements for supply and / or carriage shall be taken in stacks as soon as possible after the stacks are made. The height, shape and size of the stacks shall be as per direction of the Engineer-in-charge but in no case shall the height of the stacks be less than the minimum as indicated in the schedule showing minimum height of stacks and shrinkage allowance.

Allowance for shrinkage and / or shrinkage shall be made as indicated below. The net quantity shall be arrived at after deduction the allowance from the measurements of fresh stack and payment for supply and or

carriage shall be made on the net quantity thus arrived at 'quantity' of any material shall always indicate such net quantity unless specifically mentioned otherwise.

- b) If for any special reason as per provisions, in any particular contract final measurements have to be taken in wagons (before unloading) at destination no deduction for shrinkage and / or shrinkage shall be made.

For carried earth supplied by the contractor the earth is to be first stacked then measured up. The items of earthwork with such carried earth include the cost of such operations. The net quantity for the purpose of payments shall be derived after deducting allowance for shrinkage and / or shrinkage as specified below. In special circumstances the Engineer-in-charge may at his sole discretion, take borrow pit measurements at source for such carried earth in which case no allowance for shrinkage and / or shrinkage is to be deducted.

- c) For conversion 314 nos. of full bricks (conventional size) will be taken to produce net 1.00 cu.m. of bats and net 1.10 cu.m. of bats to produce net 1.00 cu.m. of khoa or metal. Unless specifically mentioned otherwise in any particular contract, 1025 kg of steam coal shall be taken as equivalent to 1.00 cu.m. (when measured in very old and / or shrinkage allowance when measured in fresh stacks). Similarly 1170 kg. of slack coal shall be taken as equivalent to 1.00 cu.m.
- d) Serviceable departmental material obtained by taking out or dismantling existing structure connect with building during execution of work shall have to be utilized in course of work for which payment will be made on the equivalent quantity corresponding to the materials so utilized at the labour rate for similar work.

#### **1.40 CONSUMPTION OF MATERIALS**

(FPS Unit etc to be omitted)

1. Consumption of different materials of construction in the corresponding contract items of work shall be computed on the basis of the quantities shown in this table, subject to the condition that in cases where there are IRC specifications the later (i.e. IRC specification) should be allowed and in other cases chart approved vide PWD. A/C Branch u/s 2809 (3)A dt. 27/4/71 should be consulted and discrepancy if any reconciled with reference to the items [10% in steel materials]
2. Where however the circumstance of works so require the Engineer-in-charge shall be competent to allow (for recorded reason) for greater variation.

**N.B. —** This table is based on the following assumptions:-

- i) That dry sand with Necessary allowance for bulking is used and
- ii) That the size of bricks used is 24.4 cm. × 11.9 cm. × 6.9 cm.
- iii) Full quantities of materials cannot be used as such due to breakage, leakage mixing with deleterious

Serial No.	Description of Items		Units	Name of materials required	Quantity of materials required.
1	12.5 mm. Cement plaster	2:1	% Sq.m.	1 Cement 2 Sand	0.64 cu.m. 1.28 cu.m.
2	12.5 mm. Cement plaster	3:1	% Sq.m.	1 Cement 2 Sand	0.457 cu.m. 1.37 cu.m.
3	12.5 mm. Cement plaster	4:1	% Sq.m.	1 Cement 2 Sand	0.35 cu.m. 1.40 cu.m.
4	12.5 mm. Cement plaster	6:1	% Sq.m.	1 Cement 2 Sand	0.23 cu.m. 1.40 cu.m.
5	6.5 mm. Cement plaster	2:1	% Sq.m.	1 Cement 2 Sand	0.35 cu.m. 0.70 cu.m.
6	6.5 mm. Cement plaster	3:1	% Sq.m.	1 Cement 2 Sand	0.259 cu.m. 0.777 cu.m.
7	6.5 mm. Cement plaster	4:1	% Sq.m.	1 Cement 2 Sand	0.20 cu.m. 0.79 cu.m.
8	19 mm. Cement plaster	3:1	% Sq.m.	1 Cement 2 Sand	0.69 cu.m. 2.07 cu.m.
9	19 mm. Cement plaster	4:1	% Sq.m.	1 Cement 2 Sand	0.518 cu.m. 2.07 cu.m.
10	19 mm. Cement plaster	6:1	% Sq.m.	1 Cement 2 Sand	0.34 cu.m. 2.07 cu.m.
11	25 mm. Cement plaster	3:1	% Sq.m.	1 Cement 2 Sand	0.91 cu.m. 2.74 cu.m.
12	25 mm. Cement plaster	4:1	% Sq.m.	1 Cement 2 Sand	0.68 cu.m. 2.74 cu.m.
13	25 mm. Cement plaster	6:1	% Sq.m.	1 Cement 2 Sand	0.46 cu.m. 2.74 cu.m.
14	38 mm. Cement plaster	6:1	% Sq.m.	1 Cement 2 Sand	0.70 cu.m. 4.20 cu.m.
15	Plaster with composite mortar	6:1:1			

Serial No.	Description of Items		Units	Name of materials required	Quantity of materials required.
	a) 6 mm. Thick		% Sq.m.	Sand Lime Cement	0.78 cu.m. 0.13 cu.m. 0.13 cu.m.
	b) 12.5 mm. Thick		% Sq.m.	Sand Lime Cement	1.38 cu.m. 0.23 cu.m. 0.23 cu.m.
	c) 19 mm. Thick		% Sq.m.	Sand Lime Cement	2.07 cu.m. 0.345 cu.m. 0.345 cu.m.
16	Plaster with Composite Mortar	9:2:1			
	a) 12.5 mm. thick		% Sq.m.	Sand Lime Cement	1.35 cu.m. 0.30 cu.m. 0.15 cu.m.
	b) 19 mm. thick		% Sq.m.	Sand Lime Cement	2.07 cu.m. 0.46 cu.m. 0.23 cu.m.
	c) 25 mm. thick		% Sq.m.	Sand Lime Cement	2.71 cu.m. 0.60 cu.m. 0.30 cu.m.
	d) 38 mm. thick		% Sq.m.	Sand Lime Cement	4.05 cu.m. 0.90 cu.m. 0.45 cu.m.
17	Sand, lime, plaster	3:1			
	a) 12.5 mm. thick		% Sq.m.	Sand Lime	0.28 cu.m. 0.64 cu.m.
	b) 19 mm. thick		% Sq.m.	Sand Lime	1.90 cu.m. 0.95 cu.m.
18	Sand, lime, plaster	3:1			
	a) 12.5 mm. thick		% Sq.m.	Sand Lime	1.37 cu.m. 0.457 cu.m.
	b) 19 mm. thick		% Sq.m.	Sand Lime	2.07 cu.m. 0.69 cu.m.
	c) 25 mm. thick		% Sq.m.	Sand Lime	2.74 cu.m. 0.91 cu.m.
19	Sand, lime, plaster	4:1			



Serial No.	Description of Items		Units	Name of materials required	Quantity of materials required.
	a) 25 mm. thick		% Sq.m.	Sand Lime	2.74 cu.m. 0.68 cu.m.
20	Cement flush pointing to brick work	4:1	% Sq.m.	1 Cement 2 Sand	0.092 cu.m. 0.366 cu.m.
21	Cement rule pointing to brick work	3:1	% Sq.m.	1 Cement 2 Sand	0.122 cu.m. 0.666 cu.m.
22	Cement flush pointing to tiled floor and curing	3:1	% Sq.m.	1 Cement 2 Sand	0.05 cu.m. 0.15 cu.m.
23	Brick work in cement mortar	3:1	% cu.m.	1 Brick 2 Cement 3 Sand	38,840 Nos. 10.67 cu.m. 32.0 cu.m.
24	Brick work in cement mortar	4:1	% cu.m.	1 Brick 2 Cement 3 Sand	38,840 Nos. 8.25 cu.m. 33.0 cu.m.
25	Brick work in cement mortar	6:1	% cu.m.	1 Brick 2 Cement 3 Sand	38,840 Nos. 5.507 cu.m. 33.0 cu.m.
26	Brick work with composite mortar	6:1:1	% cu.m.	1 Brick 2 Sand 3 Lime 4 Cement	38,840 Nos. 32.00 cu.m. 6.33 cu.m. 5.33 cu.m.
27	Brick work with composite mortar	9:2:1	% cu.m.	1 Brick 2 Sand 3 Lime 4 Cement	38,840 Nos. 32.00 cu.m. 7.00 cu.m. 3.50 cu.m.
28	Brick work in lime mortar	2:1	% cu.m.	1 Brick 2 Lime 3 Surki	38,840 Nos. 15.00 cu.m. 30.00 cu.m.
29	Brick work in lime mortar	3:1	% cu.m.	1 Brick 2 Surki 3 Lime	38,840 Nos. 32.00 cu.m. 10.50 cu.m.
30	Brick work in lime mortar	4:1	% cu.m.	1 Brick 2 Surki 3 Lime	38,840 Nos. 33.00 cu.m. 8.25 cu.m.
31	Random stone masonry work in cement mortar	6:1	% cu.m.	1 Boulders 2 Cement 3 Sand	95.00 cu.m. 8.00 cu.m. 50.00 cu.m.

Serial No.	Description of Items		Units	Name of materials required	Quantity of materials required.
32	12.5 cm thick brick wall (plain or with HB netting)	4:1	% Sq.m.	1 Brick 2 Cement 3 Sand	49,510 Nos. 0.915 cu.m. 3.66 cu.m.
33	7.5 cm thick brick wall	3:1	% Sq.m.	1 Brick 2 Cement 3 Sand	30,140 Nos. 0.762 cu.m. 2.285 cu.m.
34	Cement concrete with Jhama chips	4:2:1	% cu.m.	1 Jhama chips (6 to 20 mm) 2 Sand 3 Cement	90 cu.m. 45 cu.m. 22.50 cu.m.
35	Cement concrete with Jhama chips	5:2:1	% cu.m.	1 Jhama chips 2 Sand 3 Cement	93 cu.m. 46.5 cu.m. 18.60 cu.m.
36	Cement concrete with Jhama khoa (32 mm down)	6:3:1	% cu.m.	1 Jhama khoa 2 Sand 3 Cement	96 cu.m. 48 cu.m. 16 cu.m.
37	Cement concrete with Jhama khoa	8:4:1	% cu.m.	1 Jhama khoa 2 Sand 3 Cement	98 cu.m. 49 cu.m. 12.2 cu.m.
38	Cement concrete with Stone chips	6:3:1	% cu.m.	1 Stone chips (6 to 20 mm) 2 Sand 3 Cement	88 cu.m. 44 cu.m. 22 cu.m.
39	Cement concrete with Stone chips	3:1½:1	% cu.m.	1 Stone chips (6 to 20 mm) 2 Sand 3 Cement	86 cu.m. 43 cu.m. 28.6 cu.m.
40	Cement concrete with Stone metal (32 mm down)	6:3:1	% cu.m.	1 Stone metal (32 mm down) 2 Sand 3 Cement	94 cu.m. 47 cu.m. 15.6 cu.m.
41	Cement concrete with Stone metal	8:4:1	% cu.m.	1 Stone metal (32 mm down) 2 Sand 3 Cement	96 cu.m. 48 cu.m. 12 cu.m.

Serial No.	Description of Items		Units	Name of materials required	Quantity of materials required.
42	25 mm artificial stone floor with jhama chips [which includes 3.2 mm thick neat cement finish]	4:2:1	% Sq.m.	1 Jhama chips (6 to 12.5mm) 2 Sand 3 Cement	2.28 cu.m. 1.14 cu.m. 0.66 cu.m.
43	19 mm artificial stone floor with jhama chips [which includes 3.2 mm thick neat cement finish]	4:2:1	% Sq.m.	1 Jhama chips (6 to 12.5mm) 2 Sand 3 Cement	1.715 cu.m. 0.858 cu.m. 0.52 cu.m.
44	25 mm artificial stone floor with stone chips [which includes 3.2 mm thick neat cement finish]	4:2:1	% Sq.m.	1 Stone chips (6 to 12.5mm) 2 Sand 3 Cement	2.23 cu.m. 1.128 cu.m. 0.65 cu.m.
45	19 mm artificial stone floor with stone chips [which includes 3.2 mm thick neat cement finish]	4:2:1	% Sq.m.	1 Stone chips (6 to 12.5mm) 2 Sand 3 Cement	1.675 cu.m. 0.84 cu.m. 0.51 cu.m.
46	38 mm artificial stone floor with stone chips [which includes 3.2 mm thick neat cement finish]	4:2:1	% Sq.m.	1 Stone chips (6 to 12.5mm) 2 Sand 3 Cement	3.85 cu.m. 1.675 cu.m. 0.93 cu.m.
47	38 mm artificial stone floor with jhama chips [which includes 3.2 mm thick neat cement finish]	4:2:1	% Sq.m.	1 Jhama chips (6 to 12.5mm) 2 Sand 3 Cement	3.42 cu.m. 1.75 cu.m. 0.97 cu.m.
48	Single brick flat soling		M <sup>2</sup>	1 Brick	32 Nos.
49	Brick-on-edge soling		M <sup>2</sup>	1 Brick	54 Nos.

**Chapter – II**  
**INSTALLATION OF TUBEWELLS**  
**General Specification & Execution**

**2.10 H.D.T.W. & M.D.T.W.**

1. Notwithstanding what has been described in the Schedule of works, drilling of different dia Tubewells will follow I.S. specification. For large diameter tubewell I.S. 2800 of 1979 should be referred for any dispute.
2. For Drilling of Heavy duty / Medium duty tubewells Engineer-in-charge should arrange to handover an area approximately 3000 metre square with length in any direction not less than 30 metres for use of the Contractors for drilling of Tubewells. After completion of work the Contractor should remove his plant and machinery and dress, level and ground as per direction of Engineer-in-charge.
3. Method of Drilling:
  - (A) The Drilling of tubewell shall be carried out in presence of Engineer-in-charge or his authorized representative not below the rank of Sub-Assistant Engineer to be suitable aquifer is available within 150 metres approx. Drilling may have to be continued in search of good aquifer beyond 150 metres below G.L. in exceptional cases when directed by the Engineer-in-charge.
  - (B) The contractor shall inform the Engineer-in-charge the type of rigs (reverse circulation and Direct Rotary) which he proposes to deploy at each and every site, for his acceptance and the work shall be taken up only on receipt of the decision of the Engineer-in-charge.
  - (C) A large quantity of water will be required for drilling of Tubewells which should be arranged by the Contractor at his own cost. The Contractor may arrange for water from nearby private tank or otherwise even by sinking of a small diameter tubewell at his cost. Drilling cost provided in the schedule is inclusive of such cost.
  - (D) Collection of sample of stratum that will be met during, is the most vital work of the entire drilling operation of a tubewell. It is the responsibility of the drilling contractor to engage experienced technical personnel to observe continuously of the strata which is being encountered with sample of strata which will be met should be observed continuously and collected for every 3 metre interval. For any change of strata sample should be collected continuously.

The strata sample should be collected and kept in a box with suitable number of compartments for every 3 metre length or for a change in strata.

Such box of strata sample should be shown to the Engineer-in-charge, who will prepare the schedule for lowering of pipes and strainers after proper design.

For any faulty collection of strata sample design of the tubewell may be faulty and the tubewell may fail. Contractor shall be held responsible for failure of the tubewell owing to such faulty collection of strata and no payment will be made for the work to the drilling contractor.

4. Tubewell Assembly:

Pipes for the tubewell assembly consisting of housing pipe, blank pipe, and bottom plug will be supplied departmentally. The tubewell assembly should be constructed by fillet weld with equal legs providing at each joint, sockets (rings) made from M.S. Flats 80 mm × 10 mm for 165.20 mm O.D. Pipe and 100 mm × 12 mm for 273 mm O.D. Pipe by rolling process and double butt weld. Second layer of welding should be done only after removing and cleaning the flux from the first layer. No extra payment for supplying sockets (rings) as stated above and welding are covered in schedule of works. The housing and welding of the tubewell assembly should be done in present of Engineer-in-charge or his authorized representative not below the rank of Sub-Assistant Engineer.

**For standard M.D.T.W.**

- A
- (i) Housing pipe of 250 mm N.B. to a length upto 42 M.
  - (ii) Blank pipe of 150 mm N.B. to a length of as required.
  - (iii) Slotted pipe of 150 mm N.B. with 75 mm × 1.6 mm slots as necessary to a length of 30.00 mt. Or more, if required, as per drawing & direction of Engineer-in-charge.
  - (iv) Standard Reducer 250 mm × 150 mm N.B.
  - (v) Bottom plug 150 mm N.B. to a length of not more than 3 metre with a cap at the bottom.
  - (vi) Centre guide — 6 nos. or more as may be necessary. Each centre guide are made from M.S. flat 50 mm × 6 mm section as per Schedule of works.
  - (vii) Top Cap.

**For standard H.D.T.W.**

- (i) Housing pipe of 350 mm N.B.. to a length upto 42 M.
- (ii) Blank pipe of 200 mm N.B. to a length as required.
- (iii) Slotted pipe of 200 mm N.B. with 75 mm × 1.6 mm slots to a length of 30 M or more, if required as per drawing and direction of Engineer-in-charge.

- (iv) Standard reducer of 350 mm × 200 mm N.B.
- (v) Bottom plug 200 mm N.B. to a length of not more than 3 metres with a cap at the bottom.
- (vi) Centre guide 6 nos. or more as may be necessary. Each center guide is made from M.S. flat 50 mm × 6 mm section as per schedule of works.
- (vii) Top cap.

**B** Slotted Pipe : Contractor will be supplied with blank ERW pipe of required diameter from the Departmental godown which he would require to carry to the workshop for making slots over the pipes as per Drawing and Specification. The slotting charges provided in the schedule is inclusive of transport cost of pipe from the Departmental godown to the workshop and then upto the site of work.

**C** Housing Pipe : The top of the housing pipe shall be kept generally 600 mm above ground level or as directed by the Engineer-in-charge.

**D** The reducer, bottom plug, center guide and top cap shall be used according to design and specification approved by the Engineer-in-charge.

**E** All pipes, reducer etc. are to be cleaned of rust, dirt. Etc. and painted both inside and outside with two coats of bituminous paint by the contractor at his own cost before installation.

**5. Gravel Treatment of Tubewell :**

After the tubewell assembly has been placed in position, the gravel has to be inserted in the annular space between the well pipe and the borehole. The contractor shall make arrangement for gravel treatment with clean and washed gravel with uniformity co-efficient of two or less. Gravel size should be 2 mm to 4 mm and also 90% of the gravel should be retained in sieve of mesh size opening of 1.6 mm or as advised by the Engineer-in-charge to meet the specific requirement in the particular site. The gravel filling should be started from the bottom of the borehole and should be continuously worked upto the bottom of the housing pipe. A check of the verticality of the housing pipe and necessary correction should be made at this stage. Therefore the gravel filling shall be done from that point upto the ground level. Care should be taken both by the contractor and the Supervising Engineer to see that gravel feeding is done all round the annular space properly during its entire operation. The contractor should be paid for gravel treatment for the quantity of gravel utilized by volumetric measurement. For this purpose the difference of stack measurement as per standard procedure of P.W. Department of Government of West Bengal, before and after work increased by 5% towards handling wastage will be the volumetric quantity admissible for payment. P.W. Department procedure to be followed in stack measurement is as follows :

List showing minimum height of stack and allowance to be deducted for sinkage and or shrinkage when measured in fresh stacks.

<b>Materials</b>	<b>Minimum Height of stacks</b>	<b>Allowance to be deducted for sinkage And / or shrinkage</b>
Stone metal, ballast, chips shingles or gravel.	32.5 cm.	1/13

**6. Verticality :**

The housing pipe shall be placed vertically inside the borehole. A tolerance of not more than 55 mm in 25 metre depth in the same direction in case of 350 mm./250 mm. N.B. housing pipe for H.D.T.W./M.D.T.W. may however be permitted as deviation for plumb. Verticality test must be arranged by the contractor with standard equipments at his cost s per I.S. 2800 of part II 1973. In case of deviation beyond the permissible tolerance mentioned above, acceptance of the well will be subject to the following conditions.

(a) A dummy of 25 metre long and 300 mm./200 mm dia. representing the pump assembly can be lowered into the housing pipe without hindrance in case of H.D.T.W./M.D.T.W.

(b) An overall reduced rate of 95% will be allowed against the billed amount of the tubewell.

**7. Development of Tubewell and Yield Test :**

The contractor shall develop the tubewell by pumping and backwashing by Air Compressor and over size vertical turbine pump of 2.5 cusec or above capacity only as per direction of the Engineer-in-charge. The following procedures shall be strictly adhered to during development.

- (i) Air surging by Air Compressor of not less than 375/250 cfm. Capacity capable of developing 200/150 psi, shall be intermittent and not continuous, Air shall be sent for 10 minutes at a stretch followed by an equal period of shut down. The operation shall be continued till all silty materials are removed. Eduction pipe shall be used where necessary in case of Surging by Air Compressor and it will be mandatory in case of drilling by direct Rotary Rigs.

- (ii) After removal of silty materials when the sand content in the water has come down to at least 20 PPM of water to be measured by a standard measuring glass, development by over size V.T. pump (2.5 to 3 cusec) should be continued for at least further 10 hours.
- (iii) The Development shall be considered as complete when the expected discharge of water is in the range of 75 cubic metre per hour to 150 cubic metre per hour (variation depending on the physical characteristics of the sub-strata formation) and the water is free from sand with a tolerance of 10 PPM of sand by volume. This is to be measured in a standard measuring glass. The contractor shall provide at site the standard measuring glass. The Engineer-in-charge or his authorized representative not below the rank of Sub-Assistant Engineer/Junior Engineer shall remain present during the process of development and shall issue a written completion certificate to that effect.
- (iv) Measurement of sand contents shall be taken after running the tubewells for 5 (five) minutes.
- (v) Development is to be taken up immediately after the tubewell assembly lowering and to be completed within 15 (fifteen) days of the lowering of well assembly. If the development of the tubewell is not taken up within the period as stipulated above, the contractor will be liable for any eventual abandonment of tubewells and no payment for the unsuccessful tubewells will be made. All costs of materials supplied to him and consumed in that particular well will also be recovered from him.

**8. Final Test / Yield Test :**

After the tubewell has been satisfactorily developed the contractor shall arrange to conduct yield test by a pump of capacity of about 2.5 to 3 cusec continuously for 6 hours and record the following tests and measurements at his own cost and equipments.

- (a) Static water level measured before starting of pumping.
- (b) Discharge measured by use of orifice gauge or 'V' Notch after the development is completed.
- (c) The variation (at least three Nos.) of water levels and corresponding discharges during yield test should be measured. Draw down should be measured by depth gauge or directly with tape. There should be an interval of 30 minutes between two consecutive readings.
- (d) After the data against 8 (c) have been obtained the well should be run for at least 6 hours continuously at the maximum, capacity of the pump set installed for development or at a 50% higher discharge than the expected yield and the corresponding discharge draw-down and sand contents before and after the 6 hours period will be recorded.



- (e) Quantity of sand in PPM of water by use of standard measuring glass at the end of yield test.
- (f) Final measurement of tubewell assembly by sounding method and verticality test of housing pipe shall be taken after cleaning the tubewell assembly of sand and silt etc. by the contractor.
- (g) The Engineer-in-charge or his authorized representative not below the rank of Assistant Engineer shall carry out the final yield test, verticality and sounding tests and issue a written certificate to the contractor.

**9. Successful and Unsuccessful Tubewells :**

- (A) Successful boreholes will be stipulated by the existence of about 30 metres of good granular aquifer materials on an average with expected discharge as follows :

AREA	DISCHARGE IN IGPH	
	H.D.T.W.	M.D.T.W.
(a) Alluvial Areas: Such as district of Murshidabad, Nadia, 24-Parganas (North) & (South), Howrah, Hooghly, Burdwan (excepting Asansol Sub-Divn.) Midnapore (East). Jalpaiguri, Coochbehar and Siliguri Sub-Divn. of Darjeeling District.	35,000	17,500
(b) Laterite Areas : Such as Asansol Sub-Divn of Burdwan District and the District of Bankura, Midnapore (West) and Birbhum.	25,000	15,000
(c) Older Alluvial Areas : Such as Malda, Uttar Dinajpur, Dakshin Dinajpur.	25,000	15,000

In case of non availability of minimum thickness of aquifer capable of yielding expected discharge as detailed above, the borehole may be treated as abandoned by an Officer not below the rank of Executive Engineer and only drilling charge will be paid.

- (B) The Engineer-in-charge or his authorized representative not below the rank of Assistant Engineer, however, reserves the right to order for lowering the tubewell assembly into the borehole where the length of aquifer is less than 30 mtr. or where the expected discharge may fall below the prescribed limit particularly in dry areas where discharge below minimum is considered beneficial for agriculture purpose.

- (C) If in exceptional cases, where lowering of tubewell assembly has been ordered in terms of 'B' (above), the discharge actually available on yield test after carrying out all items of works strictly as per specification. If found too low for economic use for agriculture purpose, the tubewell may be declared abandoned by the Superintending Engineer (Agri-Irrign.) on going through the records of the case, and the contractor will be entitled for payment as per schedule for all items of work executed by him. In such case of abandoned tubewell the contractor should immediately arrange for withdrawal of pipe assembly to the maximum extent possible within 7 (seven) days from the date of intimation to him. The quantity of pipe that cannot be withdrawn will be treated as consumed against the particular contract.

**10. Supervision :**

All works such as drilling, recording of formation of tubewell and its lowering, development, gravel packing etc. are to be conducted strictly under the supervision of Engineer-in-charge or his authorized representative.

**DRILLING OF TUBEWELLS**  
**General Specification & Execution**

**2.20 L.D.T.W. & S.T.W.**

1. All works are to be carried out in proper manner and as per best practice, according to the direction of the Engineer-in-charge to his satisfaction.
2. Before boring of L.D.T.W. / S.T.W. the Engineer-in-charge will hand over the pin pointed sites to the contractor to have access to work site with his plants and machinery. If necessary, approach road, temporary culverts etc. may have to be constructed / repaired at his own cost for access to the work site.
- 3.(a) Method of Boring : The boring of the Tube-well (L.D.T.W. / S.T.W.) shall be carried out in presence of the Engineer-in-charge or his authorized representatives not below the rank of Sub-Assistant Engineer till suitable aquifer of the required length is available within 66 metres approximately. However, the boring may be continued in search of good aquifer beyond 66 m below G.L. in exceptional cases when directed by the Engineer-in-charge.

- (b) The boring operation will be done by water jet system through any type of soil of suitable size to facilitate smooth lowering of the Tube-well assembly without any hindrance. The water jet machine along with other equipments viz. drilling pipes etc. of adequate length should be arranged by the contractor for boring of the tube-wells of required depth.
  - (c) The contractor shall make his own arrangement at his own cost to procure water for boring operation or drinking and other purpose of his working personnel.
- 4. Tube-well Assembly :** The materials for tube-well assembly consisting of E.R.W. pipes with sockets, G.I. pipes with sockets and brass jacketed strainer will be supplied departmentally and the fittings/ specials mainly heavy type bell-mouth reducing sockets, steel cutter pieces and G.I. Top caps are to be supplied by the contractor. The payments of those specials will be made as per provision made in the working schedules. Jointing of pipes with threaded sockets, lowering of the tube-well assembly will be done in presence of the Engineer-in-charge or his authorized representative not below the rank of S.A.E.

The materials of the Tube-well assembly of a standard L.D.T.W./ S.T.W. are given below :

**(a) STANDARD L.D.T.W.**

- (i) Housing pipe (E.R.W.) of 150 mm N.B. to a length of 24 m.
- (ii) G.I. pipes of 80 mm N.B. to a length of 30 m.
- (iii) Brass jacketed strainer of 80 mm N.B. to a length of 12 m.
- (iv) Standard 150 mm / 80 mm dia. Heavy Type bellmouth reducing socket – 1 No.
- (v) Steel plug cutter piece of 80 mm dia. Upto 450 mm long with threaded socket.
- (vi) G.I. top cap of 150 mm dia. – 1 No.

**(b) STANDARD S.T.W.**

- (i) G.I. pipes of 80 mm N.B. to a length of 54 m.
- (ii) Brass Jacketed strainer of 80 mm N.B. to a length of 12 m.

- (iii) Steel plug cutter piece of 80 mm. dia. Upto a length of 450 mm. with threaded sockets.
- (iv) G.I. Top Cap of 8 mm. dia. – 1 No.

**(c) HOUSING PIPE :**

The top of the housing pipe shall generally be kept 600 mm. above G.L. or as directed by the Engineer-in-charge.

**(d) JOINTING OF PIPES OF SPECIALS :**

The specials viz. reducer, plug cutter piece, top cap etc. shall be used according to the design and specification and as per direction of the Engineer-in-charge.

E.R.W. pipes, reducer, etc. are to be cleaned of rust, dirt and painted both inside and outside with two coats bitumastic paint by the contractor at his own cost before installation. The threads of the pipes, sockets and specials should be cleaned with wire brush and jointing of pipes will be done using zinc oxide (Havoc zinc) to make leak proof joints.

**(e) COLLECTION OF STRATA SAMPLES :**

Records of every day progress in respect of boring of Tube-wells and of strata passed through shall be kept by the contractor. Samples of lithographic formation shall have to be collected by the contractor at every 3 m. depth and at every change of layer. The collected samples shall be kept in a suitable box with depth records and necessary description. These along with the strata chart shall be given to the Engineer-in-charge or his authorized representative not below the rank of Assistant Engineer for preparation assembly chart. For any faulty collection of strata samples, the design of the Tube-wells may be faulty and the Tube-well may fail and in that case the agency shall be held responsible for failure of the Tubewell owing to such faulty collection of strata and no payment will be made for the work to the contractor.

**5. COARSE SAND TREATMENT OF TUBEWELLS:**

After lowering of Tube-well assembly in position, the annular space between the well pipe and the bore holes is to be filled up with approved coarse sand. In case of L.D.T.W. the filling up of the sand upto the bottom of the housing pipe shall be made properly and check of verticality of the Housing pipe should be made at this stage. Care should be taken both by the contractor and the supervising Engineer to see that the annular space is properly filled up with sand during the entire operation. After the check of

verticality the portion of the Housing pipe from G.L. to the bottom end will be filled up with sand.

**6. TEST OF VERTICALITY :**

The Housing pipe shall be placed vertically inside bore hole and the test of verticality will be carried out by actually installing a submersible pump or a prototype truly resembling the pump to be supplied by the department.

**7. DEVELOPMENT OF TUBEWELL:**

The development of the Tubewell shall be done by using oversize submersible and centrifugal pump for L.D.T.W. and S.T.W. respectively, immediately after lowering of the Tubewell assembly and completed within 7 days from the date of lowering. The pump and the Engine will be arranged by the contractor. The pumping operation will be continued for 8 hrs. / day for a minimum period of 2 days or as directed by the Engineer-in-charge. The development may be considered complete when sand free water is obtained with a tolerance of 10 PPM of sand by volume in sample collected after an hour of continuous run. After satisfactory completion of development of whole of the plug-cutter piece fitted at the bottom of the Tube-well should be plugged by dropping the plug piece inside the 80 mm dia. G.I. pipe carefully. If the development of the Tube-well is not taken up within the period as mentioned above, the contractor will be liable for any eventual abandonment of the Tube-well and no payment for this will be made. All cost of materials supplied to the contractor and consumed in that particular well will be recovered from him.

**(A) FINAL TEST AND YIELD TEST :**

After the Tube-well has been satisfactorily developed the contractor shall arrange to conduct yield test and record the following test and measurement at his own cost and equipments.

- (i) Static water level measured before starting of pumping.
- (ii) Discharge measured by use of V-notch or orifice metres.
- (iii) The variation (at least 3 Nos.) of water levels and corresponding discharges during yield test should be measured, draw down should be measured by Depth Gauge or directly with tape there should be an interval of 30 minutes between two consecutive readings.
- (iv) Quantity of sand in p.p.m. of water by use of standard measuring glass at the end of yield test.

- (v) Final measurement of Tube-well assembly by sounding method and verticality Test of Housing pipe.
- (vi) The Engineer-in-charge or his authorized representative not below the rank of Assistant Engineer shall carry out the final yield test, verticality test, and sounding of tubewell assembly and issue a written test certificate to the contractor.

**9. SUCCESSFUL & UNSUCCESSFUL TUBE-WELLS :**

- (i) The successful bore holes will be stipulated by the existence of about 12 m. of good granular aquifer, materials on an average with the expected discharge within the range of 4000 to 5000 imp. Gallons / hr.

In case of non-availability of minimum thickness of aquifer capable of yielding expected discharge as mentioned above the bore holes may be treated as abandoned by an Officer not below the rank of Executive Engineer and in such case only the boring charge will be paid.

- (ii) The Engineer-in-charge or his authorized representative not below the rank of Assistant Engineer reserves the right to order for lowering the Tubewell assembly in to the bore holes where the length of available aquifer is less than 12 m or where the expected discharge may fall below prescribed limit particularly in dry areas where discharge below minimum is considered beneficial for the purpose of irrigation.
- (iii) If in exceptional cases where lowering of the Tubewell has been completed and the discharge actually available on yield test after carrying out all items of work as per specification appears to be low for economic use for irrigation purposes, the tubewells may be declared abandoned by the Superintending Engineer (A-I) on going through the records of the case and the contractor will be entitled for getting payment as per schedule for all items of work executed by him. In such case of abandoned tubewells the contractor should immediately arrange for withdrawal of pipe assembly to the maximum extent possible within 7 days from the date of intimation. The quantity of pipe that cannot be withdrawn will be treated as consumed against the particular work.

**10. SUPERVISION :**

All works such as boring, lowering, development, recording of the tube-well particulars etc. are to be conducted strictly under the supervision of the Engineer-in-charge or his authorized representative.

Chapter – III

**DIVERSION SCHEMES**

General Specification, Execution, Material, Modes of Measurement & Consumption of Materials.

**3.10 General Specification & Execution:**

**1. EARTH FILLING :**

The space around the structure will have to be cleared on all loose debris and filled with earth in 15 cm. layers and will have to be rammed in layers by watering after breaking clods. The filling work shall be done in steps to keep pace with progress of masonry work. The rate of earth filling shall include excavation, carriage, lead and lifts, watering, ramming and breaking clods in all cases of filling work by earth and shall also apply to preparation of canal banks etc.

**2. SAND FILLING :**

The sub grade shall be leveled to profile and rammed before sand filling. Sand shall be spread in 15 cm. layers uniformly, watered and rammed.

**3. (a) RUBBLE MASONRY :**

Rubble masonry with hard or with laterite (as specified) shall be in cement mortar and the rate would include racking out joints on exposed faces and flash dabbing of joints on other faces, the boulders being laid flat.

The work is to be done in a manner so that no voids are left in the masonry. The previously constructed layer shall be thoroughly cleaned by wire brush before applying mortar for fresh work. For masonry work, the mortar is to be laid first in good quantity and boulders of appropriate size put in the passed down by shaking to fit properly. After this is done, small spawls may be inserted to fill in the intermediate spaces and the mortar squeezed out to ensure thorough compactness of the work **TROWELS MUST NOT BE USED FOR APPLYING MORTARS**, but full pan loads of mortar is to be laid. Finishing is to be done by brush or similar materials pressing the mortar into the pockets.

Weep holes may be left as formed holes for Wing Walls and abutments at levels specified or directed. The exposed faces of masonry should be more or less in line or in plain according to the shape shown. Exposed joints are to be racked out to a depth approximately equal to twice the thickness of the joint. Unexposed faces of abutments, breast wall etc. are to be dabbed with sand cement mortar so that all gaps in joints are properly covered. The dabbing is to be done with comparatively stiff mortar and pressed into the joint so that the same may fill the gap properly. Not more than one foot dismantled and re-erected at the cost of the contractor. Boulders are to be laid flat with bigger and longer pieces at the exposed joints.

The rate for rubble masonry is exclusive of face block work but inclusive of racking out the exposed faces and dabbing of the joints in unexposed faces, unfinished surface should not be stepped steeper than 1 rise in 2.5 horizontal. Pointing work of exposed faces should be made with cement mortar (1:3) using little water as possible and making the pointed joints smooth and in one plane. No pointing will be necessary for unexposed face, which will be covered by earth.

Only fresh, clean and hard boulders are to be used for rubble masonry. There should be no skin in such boulders. Major portion of the boulders should be of size of about 40 Kg. Spawls of different sizes may be required for filling up intermediate spaces. Laterite may be used if it is hard and permitted by the Engineer-in-charge in writing.

Rubble masonry in arch portion will have to be done very carefully. Masonry should only be started after the centering is made strongly and passed. Earth fill centering may also be made in place of steel or timber centering at the same cost but in that case earth fill must be very thoroughly rammed and bituminous centering paper used over it before starting masonry. The rate of centering in such a case is inclusive of filling and ramming earth true to shape and removing those later on. Cost of centering will be paid separately. Masonry in arches should always be done at right angles to the inner curve and with specially selected boulder at the inner surface. The outer surface need not be smooth but should be left rough but the joints properly filled with mortar. Laterite boulder when allowed to be used in rubble masonry works should thoroughly soaked in water before used.

### **3. PITCHING WORK :**

The pitching work shall include the preparation of subgrade including watering and ramming as per direction of the Engineer-in-charge and no extra payment shall be made for this. A layer of filter may be laid under the boulder pitching the voids of which are to be packed with spawls. Boulder pitching may be made with any hard stone (Quarried or collected). Locally available laterite may also be used which should be hard enough and approved by the Engineer-in-charge. Stones are to be pitched end-wise i.e. length at right angles to face of pitching. Size of the boulders should be less than 20 Kgs. unless specified, boulder pitching work will not be caulked with cement-mortar.

### **4. HUME PIPE WORKS :**

The spun pipes and collars will be given free by the department from the Government Yard. The works in the item shall include labour charges for laying, fitting, fixing as per drawing and direction including transporting the same from the departmental yard. The prices are to be placed on a good layer of cement mortar on floor for proper cushioning. Before fitting the pipes within the collars, the extreme 8 cm. width of the outside surface of the pipe



and inside face of the collars should be thoroughly roughened for proper adherence of cement mortar for caulking. Special care shall be taken for caulking and the joints should not be covered before it is approved in writing. The rate shall include all works including caulking.

Exact lengths of pipes are to be obtained by the contractor and if necessary pipes may be cut by the contractor at his cost. Loss or breakage of pipes and collars during loading, transport or unloading or placing would be entirely contractor's liability and necessary deduction at penal rates may be made. Pipes and collars having cracks or severe dents should not be used in works. If the work necessitate cutting of pipes, the edges are to be finished smooth with cement mortar (1:3) and the rate of the item shall include such works. If cuts are to be made in the pipe for passage of water, fixing of one pipe with another, fixing of vent holes in hume pipes, making the edge at right angles or flush with surface etc. including finishing the edge with 1:3 cement mortar. The contractor will have to do so within the tendered rate.

#### **5. EARTHWORK :**

The contractor will have to arrange for camps, huts if required for the labourers on the canal banks or on waster land to be demarcated by the Engineer-in-charge for the purpose unless he can arrange amicably (and produce sufficient proof of having done so to the Engineer-in-charge) camping grounds elsewhere. Camp sites must not be located near to existing villages.

The contractor will have to arrange his excavation programme so that the deeper portions of excavation are completed before monsoon. If permitted under the contract time limit. They may continue the work during the monsoon with suitable arrangements for dewatering etc. for which no extra payment would be allowed. All bars, witness etc. shall be removed before a reach can be taken as complete.

The rate of excavation will include cost of cutting and removal of bushy jungles, root of tree and stumps of all sizes as already detailed in Sl. 1 above. Site of work will include both the site of excavation and the site of throw of spoils.

Where the top soil is hard and the time limit allows working in the rainy season, the contractor may arrange his programmers in such a manner as to excavate the hard soil during the rainy season without violating the previous of clauses of tender with prior approval of the Engineer-in-charge. In case the contractor arranges water for moistening the hard soil for excavation in dry weather, no extra rate can be paid for such watering.

For the purpose of canal or foundation excavation, soil will be classified as detailed below :

**CLASSIFICATION (A) :**

Local soil, soil mixed with moorum or kankar or gravel, sticky soil, silt dry or moist, slushy silt.

This will include soil as noticed in the cultivable lands or cultivable waste land locally in the region as also soil which contains moorum, kankar or gravel up to 50% as determined by eye estimation. Sticky soil also include such local soil which will adhere to spade making excavation difficult but will not contain more than about 10% (by eye estimation) of moorum, kankar or gravel. This can be excavated by spade in all seasons.

Slit dry or moist will include only such kinds of soil which flows down from the spoil bank, beam or slopes during rainfall run off or otherwise, on the bed of canal fully or partly excavated.

Slushy slit include those kinds of slit which cannot be dried by time to time dewatering and would need removal by pan or bucket. While excavating slushy slit only the central 3 metre portion should be removed by pans or buckets and the area dewatered so that the ramming silt gets dried up and is then classified as silt dry or moist.

Removal of silt deposited during the execution of the work in question will be the responsibility of the contractor and he will have to remove the silt at his own cost.

**CLASSIFICATION (B) :**

Moorum, kankar and gravel, compact moorum soil mixed with moorum, kankar or ghooting and very much weathered rock.

i) **MOORUM, KANKAR AND GRAVEL :**

This will include soils having moorum or gravel or shingles more than 50% (approx.) as constituents. Approved quality of gravel and shingles that will be obtained from excavation of such soil should be stacked, if so desired by the Engineer-in-charge for which separate payment will be made. Payment will be made on stack measurements with necessary deductions as mentioned separately.

ii) **COMPACT MOORUM-VERY MUCH WEATHERED ROCK :**

This include moorum obtained in lump and not yield to pressure of hand. This will also include very much weathered rock which when excavated by pick axes comes out in small pieces and is powdered by spade. Undisturbed 8 cm. cube of such rock yields to hand pressure when moistened with water.

iii) **STICKY SOIL MIXED WITH MOORUM, KANKAR OR GHOOTING :**

This soil when dry cannot be excavated by spades but will have to be excavated by pick axis. Undisturbed 8 cm. cube of such soil will not yield to

hand. Pressure when dry but will yield on application of water. This soil can be excavated by spade when properly moistened with water.

**CLASSIFICATION (C) :**

**SOFT WEATHERED ROCK OR SOFT LATERITE :**

This includes soft weathered rock, which can be excavated by pick axes and comes out in small pieces. Undisturbed 8 cm. cube of such rock will not yield to hand pressure or by application of water but will easily disintegrate into small particles by hitting with 1 kg. hammer.

This item will also include soft laterite stone or laterite boulders. Laterite under this item will however come out in lumps with some percentage in powder form. Undisturbed 8 cm. cube of such laterite cannot be broken or crumbed by hand pressure nor will it disintegrate by the application of water but will easily disintegrate when hit with an 1 kg. hammer.

**CLASSIFICATION (D) :**

**HARD WEATHERED ROCK OR HARD LATERITE :**

Weathered rock will be such rock which may be dislodged by pickaxes, crowbars or demolition tools. Weathered rock will not have fresh and clean surface like hard and fresh rocks. Such rocks cannot be disintegrated easily by hitting with a 1 kg. hammer. This will generally come out in lumps. This item will also include hard, will form laterite stone to be removed by pickaxes, crowbars, chisel and hammer, demolition tools etc. Hard laterite is fit for being used in masonry (if proper size be obtained), so far as hardness and texture is concerned, whereas soft laterite is not fit.

In case the contractors intend taking recourse to blasting for excavation of this or any of the above type of materials, there would be no objection but for that purpose, the classification of the items will remain unchanged.

While excavation hard weathered rock or hand laterite come lump boulders of sizes 20 cm. and above may be obtained which may be fit for being used in rock toe or pitching work. This quality of boulders that can be stacked will be determined by the Engineer-in-charge and his decision on this is final and binding on the contractor. Such boulders will have to be stacked either on the spoil bank or on the toe as will be directed by the Engineer-in-charge and his decision on this is final and binding on the contractor. Such boulders will have to be stacked either on the spoil bank or on the toe as will be directed by the Engineer-in-charge. Payment for excavation of such weathered rock or laterite will be as per section measurement whereas payment for stacking will be as per stack measurement less 1/7 th of its volume.

Only the harder type of weathered rock or laterite of sizes 20 cm. above are to be stacked and if either softer materials or smaller sizes of materials are mixed, these will be removed and restacked at contractor's cost and the removed materials thrown into spoil banks.

**CLASSIFICATION (E):**

**HARD ROCK**

This includes such rocks, which would require removal by blasting where solid formation exists. Before taking up this item, the formal permission of the Engineer-in-charge will have to be obtained. Only those rocks, which have fresh and hard surface without the usual stains and discoloring rock, will come under this category.

For blasting work, the contractor must possess a license for using the storing gelignite or gunpowder. A properly trained and licensed fireman should be engaged for handling of explosive and blasting. Particular care is to be taken for blasting near homesteads so that the rock splinters may be away from the homesteads and not towards the same. Blasting should be done only in predetermined hours fixed in consultation with the Engineer-in-charge and giving at least 5 minutes time after issue of warning bell or siren. 'All Clear' signal is also required after the last blast is made. A full record of the blast holes charged and the number of blasting counted is to be entered in the Work Instruction Book. In this connection, the instruction of the Chief Mining Engineer regarding operations is to be followed.

Excavated hard rock must not be dumped on the spoil banks but made in regular stack at the stacking site.

Separate stacks will have to be made for hard rock materials coming out from the excavation for classifications, above for the following sizes.

- i) Boulders of size 15 cm. and above.
- ii) Chellies and ballast of sizes 15 cm.

Payment for such stacking will be made separately after necessary deduction as mentioned separately.

Samples of different classification of soil will be maintained in the office of the Executive Engineer and would indicate about the general grouping. Soils to be excavated are to be classified according to physical properties of the samples so reserved.

**6. TURFING :**

Before doing the turfing work, the surface should be dressed properly, consolidated by ramming with necessary cutting or filling as required to require profile and slope. The Quality of turf should be got approved by the Engineer-in-charge. Turfing should be cut with at least 5 cm. thick earth and placed position so as not to have gap left in between. Over lapping on all

sides should be desirable. After laying the turfs it should be beaten with flat wooden rammers properly by application of water so that it adheres to the original surface. Watering should be continued till the grass be grown. Payment of royalties etc. if any, would be contractor's responsibilities. The rate of item includes all works indicated above.

**7. MISCELLANEOUS:**

(1) Weep Holes should be laid with a gradient of 1 in 5 above the design water level. Suitable filters are to be provided at back for which no extra payment would be payable.

(2) Sand to be used for works may be river sand but it should be free from organic matter clay or silt. Sand must always be clean. Fine sand shall not be used for masonry or concrete works.

(3) Stone materials to be used for the purpose of concreting must be from hard and fresh stones and should not have chips with weathered skins or discoloured surface. Screening and/or washing will have to be done at contractor's cost if these are not clean or contain dust.

(4) All works involving cement such as concrete, masonry, plastering, pointing etc. should be properly cured which should be started within 12 hours of the work in any layer at any portion and should be continued for a period of 8 weeks during which period it should be kept constantly moist. Curing of complete work may be made by moist sand. No separate payment will be made for curing. In case richer proportion of concrete or mortar is to be used in any cement concrete work including R.C. other than specified, under instruction of the Engineer-in-charge in writing, extra cost of cement will only be allowed including cost of carrying and handling.

(5) Cement plastering will have to be done by the contractor when such work is particularly required and ordered by the Engineer-in-charge for specific reasons, but when the plastering is required for correction of shape in concrete or masonry, no extra payment will be made.

(6) Where gates are to be fitted, the contractor will have to fit up the gates including fixing foundation bolts etc. This will include fitting of Built-in-parts, setting up the gates including fixing cannels and setting up to joists. All gate parts will be issued free from departmental stores and the rate is inclusive of transport charges from concerned Sub-Divisional head quarters. Steel parts usually to be in contact with water are to be painted with anti corrosive blank bituminous paints in two coats.

(7) Diversion work and approaches are to be made as per directions of the Engineer-in-charge. The Diversion road where necessary should be maintained by the contractor of the structure till completion of the structure for which no separate payment would be made.

(8) The rates for different items except where specially mentioned should hold good for all places of the structures viz., the foundation and super-structures and no claim for lead or lift will be entertained.

(9) All rates in the items (except where mentioned otherwise) include cost of carriage of required materials upto an initial lead of 8 km. If the worksite be beyond the initial lead of 8 km. Extra rate for carriage of the materials may be allowed, for which provisions have been made in the printed schedule.

(10) Grooves or plubs will have to be kept in successive layers of concrete work in piers, abutments, wing walls, floor etc. cement gholia of proportion of 1:10 by volume has to be applied on the old surface before laying the next layer. No extra payments will be made for this.

Unless specially mentioned otherwise, the following modes of measurements shall be applied.

### 3.20 Mode of Measurements

#### 1. EARTHWORK:

(a) Earthwork in excavation of canals of blanking to be measured by suction measurement or pit measurements irrespective of the size of banking or cutting as decided by the Engineer-in-charge to have accuracy by the measurements. But, for excavation of original canals, section measurements shall be compulsory if the bed width of the canal exceeds 10 metres.

Deduction for voids in sectional measurements of finished banking volume will be made only as follows:

(i)	Carriage by head load before 1 <sup>st</sup> monsoon, deduction.	...	10%
(ii)	Carriage by head load before 2 <sup>nd</sup> monsoon, deduction.	...	4%
(iii)	Carriage by truck before 1 <sup>st</sup> monsoon, deduction.	...	4%
(iv)	Carriage by truck before 2 <sup>nd</sup> monsoon, deduction.	...	4%

No deduction for voids in section measurements would be made if the carriage was made either by head load or by truck but measured after 2<sup>nd</sup> monsoon.

(b) Measurement of excavation of foundation trenches will be taken on the basis of actual excavation with as minimum a side slope as possible consistent with the nature of soil. Generally, the sides of foundation trenches shall be made to plumb where nature of soil admits of it or they may be stepped back or shored carefully where they show a tendency to fall in.

(c) For the classification of canal excavation work, soil will be classified as under :

(i) Local soil / soil mixed with moorum or kankar / silt dry or moist / slushy silt / sticky soil.

- (ii) Moorum, kankar or Gravel / Compact Moorum / very much weathered rock / sticky soil mixed with moorum or ghooting.
- (iii) Soft weathered rock or soft laterite.
- (iv) Hard weathered rock or hard Laterite.
- (v) Hard Rock.

The process of classification would be as detailed in the additional terms and specification boulders either laterite boulders of sizes 15 cm. and above obtained by the excavation will have to be stacked as per direction of the Engineer-in-charge. Extra rate for such stacking may be allowed and payment for excavation of such materials will be as per section measurement or pit measurement where as payment for stacking will be as per stack measurement less deduction for voids as standardized.

For the purpose of tallying, the full stack measurement without void deduction etc. should be at least 30% more than sectional measurements. In case of shortfall in stack measurements deduction from the section measurement would be made for payment of excavation item. Extra payment for stacking shall include the cost of breaking, and stacking in position as per direction of the Engineer-in-charge.

## 2. LEADS AND LIFTS:

For canal excavation and for banks and embankments, the item of excavation will be within an initial lead of 15 M. and an initial lift of 2 M. Additional lead and lift will be in multiples of 30 M. and 2 M. respectively. The measurement of lead and lift will be the horizontal and vertical distance between Center of Gr. of the excavated zone removed and C.G. of the spoil bank made out of excavation. To avoid the difficulties in calculating the C.G. correctly for lead and lift measurements, the lift will be taken as the vertical distance of  $\frac{3}{8}$ <sup>th</sup> the height of the bank from the ground level plus  $\frac{3}{8}$ <sup>th</sup> depth of the excavated section from the same level.

Lead and lift would be calculated for the total work in the section concerned and the same lead and lift would be applicable for all classification irrespective of the location of different soil.

However, baren lifts would be considered in case of barriers as the where applicable.

## 3. EARTH FILLING:

Measurement on the space filled up around the structures after deposition of soil in layers breaking clods, watering and ramming complete so that compact space is considered and not the loose volume. Alternatively measurement of earth filling can be done on the basis of quantity of excavation paid for less the volume occupied by the structure.

4. SAND FILLING:

As above.

5. TURFING:

Measurements will be allowed only on transplanted surface area where grass grown without gaps. No measurement would be taken where grass has not been grown though transplanted, not on areas having gaps between grown grass.

6. FILLING WORKS:

Salballah to be measured without back and the diameter to be calculated at 1/3<sup>rd</sup> distance of length from the thicker end.

Measurement to drive length should be based on length of the pin (Salballah) actually driven under the original ground surface.

**3.30 CONSUMPTION OF MATERIALS FOR DIVERSION SCHEMES:**

Sl.No.	Item	Unit	Materials	Quantities required
1.	Boulder masonry work in cement mortar (1:4)	M <sup>3</sup>	Cement	0.14 M.T.
			Sand	0.45 M <sup>3</sup>
			Boulder	0.90 M <sup>3</sup>
	(1:5)	M <sup>3</sup>	Cement	0.12 M.T.
			Sand	0.40 M <sup>3</sup>
			Boulder	0.90 M <sup>3</sup>
2.	Single brick flat soling	%M <sup>2</sup>	Bricks	3280 Nos.
3.	Neat cement finishing	M <sup>2</sup>	Cement	0.0022 MT.
4.	Wearing course with stone chips (1:1 ½:3)	M <sup>3</sup>	Sand	0.43 M <sup>3</sup>
			Cement	0.40 M.T.
			Chips	0.86 M <sup>3</sup>
5.	Caulking the exposed joints of pitching work with cement mortar (1:4).	M <sup>2</sup>	Cement	0.007 M.T.
			Sand	0.023 M <sup>3</sup>
6.	10 cm. thick (1:3:6) in cast in situ block with (1:3) sand cement plastering on top for finishing.	%M <sup>2</sup>	Cement	2.634 M.T.
			Sand	5.133 M <sup>3</sup>
			Gravel	9.55 M <sup>3</sup>
7.	Grouting brick pitching with cement mortar (1:6).		Cement	0.0018 M.T.
			Sand	0.01 M <sup>3</sup>



8.	R.C.C. face blocks (1:2:4) 5 cm thick set in cement mortar (1:3).		Cement	0.0342 M.T.
			Sand	0.022 M <sup>3</sup>
			Stone chips	0.044 M <sup>3</sup>
9.	Fixing spun pipes and collars with cement mortar (1:3)			
	i) 10 cm dia.	Per Joint	Cement	0.002 M.T.
			Sand	0.01 M <sup>3</sup>
	ii) 15 cm dia.	Per Joint	Cement	0.003 M.T.
			Sand	0.01 M <sup>3</sup>
	iii) 22.5 cm dia.	Per Joint	Cement	0.005 M.T.
			Sand	0.02 M <sup>3</sup>
	iv) 30 cm dia.	Per Joint	Cement	0.007 M.T.
			Sand	0.02 M <sup>3</sup>
	v) 45 cm dia.	Per Joint	Cement	0.009 M.T.
			Sand	0.03 M <sup>3</sup>
	vi) 60 cm dia.	Per Joint	Cement	0.011 M.T.
			Sand	0.03 M <sup>3</sup>
	vii) 75 cm dia.	Per Joint	Cement	0.013 M.T.
			Sand	0.04 M <sup>3</sup>
	viii) 90 cm dia.	Per Joint	Cement	0.016 M.T.
			Sand	0.04 M <sup>3</sup>
	ix) 105 cm dia.	Per Joint	Cement	0.019 M.T.
			Sand	0.05 M <sup>3</sup>
	x) 120 cm dia.	Per Joint	Cement	0.022 M.T.
			Sand	0.05 M <sup>3</sup>
	xi) 135 cm dia.	Per Joint	Cement	0.025 M.T.
			Sand	0.06 M <sup>3</sup>
10.	Boulder Pitching work	M <sup>3</sup>	Boulder	1.00 M <sup>3</sup>

**SCHEDULE SHOWING MINIMUM HEIGHT OF STACKS AND THE SHRINKAGE ALLOWANCE TO BE DEDUCTED FROM GROSS VOLUME OF MEASURED STACKS.**

<b>Materials</b>	<b>Minimum height of stacks</b>	<b>shrinkage allowance</b>
Carried Earth	30 cm.	1/9
Moorum	39 cm.	1/13
Lime	60 cm.	1/5
Surki	60 cm.	1/4
Sand	56 cm.	1/8
Jhama Khoa	36 cm.	1/9
Jhama Bats	49 cm.	1/7
Brick bats	49 cm.	1/7
Stone boulders or laterites below 15 cm. size.	45 cm.	1/9
Stone Boulder 15 cm. or above size	45 cm. 49 cm.	1/9 1/7
Stone chips, singles or gravels	39 cm.	1/13
Rubbish	36 cm.	1/9
Steam coal or slack coal	56 cm.	1/8

Chapter — IV

**LIFT IRRIGATION SCHEMES**

**INSTALLATION, OPERATION & MAINTENANCE**

**A. Installation**

In the State of West Bengal many schemes have been installed on rivers / beels and other perennial sources for lifting of water either by Diesel Engine driven Centrifugal pumps or by Electro-motor pump sets for the purpose of irrigation. According to the Bank conditions and the fluctuations of water level during dry and rainy season as well as other conditions, the pump sets have been installed in pump houses / steel barges / on portable trolley covered by detachable shroud. Main objective is to protect the costly pump sets from unfavourable seasonal weather conditions prevalent in this State. Main points, in regard to installation of pump sets, which should be followed for better performance are as follows :-

- 1) Pump-sets should be securely mounted on foundation bed / channels etc. as the case may be, to prevent any undue vibration.
- 2) Suction line leading from the pump in-let point suction sump should be as streamlined as possible i.e. minimum number of bends particularly sharp bends is to be avoided, in order to avoid any air-trapping. Air-trapped in the suction line may ultimately loose the priming of the pump which may prevent and / or cause problem in the pump. In many cases a nominal quantity of air-trapped in the suction line may not hamper operating the pump but it generally will cause noisy sound.
- 3) Foot valves fitted at the end of the suction line and submerged in the suction sump should be submerged in the up-right condition and a clear gap of at-least 0.46 m to 0.77 m should be maintained from the bottom of the rivers / beel bed so that the foot valve openings are not clogged at any material point of time. Moreover, it has been observed that many suspended vegetable / foreign particles are mixed up in water particularly in the rainy season. To avoid free entry of those particles to the foot valves, it is advisable to provide suitable screens around the foot valves.
- 4) Delivery line leading from the pump delivery point should be properly aligned and fixed to avoid any leakage of water in the pump house / barge.
- 5) In most cases, the actual command is situated at a higher elevation than the pump installation point and shore manifolds / surge tanks and recently introduced distribution chambers are located constructed at a suitable place at the beginning of the command area for uniform distribution water throughout the command. In such cases one non-return valve, preferably of I.S.I. marked quality, may be provided just before the shore manifolds etc. In such of the delivery line having by-pass arrangement. This will ultimately help in fresh priming of pumps after rectification of the defects in the suction line, as discussed subsequently in the operation of pump-sets.
- 6) In schemes where pump-sets are installed on steel barges, suitable priming chamber may be provided in the barges itself between inlet of pump and the suction sump. Normally the size of the priming chamber should be such

so that the total volume of water in the priming chamber should be at least 2.5 times the volume of water that can be accommodated in the pump itself. This arrangement will make the pump a self-priming one and the most trouble-some operation of priming in day-to-day performance of pump can be avoided.

## **B. Operation**

During the working season pump sets are generally pressed into service everyday to meet the requirements of irrigation of the beneficiaries located in the declared command of the schemes. In such case, following routine checks should be performed before starting of the pump sets at the days beginning and closing at the days end:-

- 1) Delivery valves should remain in closed condition.
- 2) The nuts and bolts etc, fixing the pumpsets in the base-frame should be checked whether there is any axial or side-play and if so those should be properly tightened up to prevent any unwanted vibration.
- 3) In case of oil bath & air-cleaner the cover should be removed and the condition of the oil should be checked whether there is any dirt / grit etc. In the event the detection of such dirt / grit the oil should be replaced and the air-cleaner is to be thoroughly cleaned with Kerosene oil and fresh oil should be poured in. This is very important as, otherwise those impurities may be inducted in the engine proper and the result may be disastrous.
- 4) Oil tank in case of Diesel engine should be checked whether there is sufficient oil in the tank for operation of the diesel engine for the intended hours operation and sufficient quantity of oil should be filled up in the tanks. Oil line leading from the tank to filter, which is most cases flexible polythene pipe, should be examined whether there is free flow from the tank to the filter.
- 5) Priming cock fitted on the pump should be opened for ascertaining the priming condition of the pump. In the event of pump being in primed conditions, water will start coming out as soon as the priming cock is opened. Otherwise, it may be construed that there is leakage in the suction line, which should be started and on attainment of the full revolution of the engine, delivery valve should be slowly opened to prevent any undue thrust on the pump sets.
- 6) At least one spout in each of the delivery line leading from shore manifolds / surge tanks / should always remain open to avoid building up of excessive pressure in the distribution system.
- 7) After the days operation, the delivery valve of the pump should be slowly closed and on closing of the same, the engine should be shut-down. Otherwise water hammer may occur particularly when the delivery line from the pump delivery point to the distribution chamber is a lengthy one.

## **C. Maintenance**

Best method of maintenance is the preventive maintenance i.e. performing the routine checks periodically to prevent major break-down of the engines. This

not only saves a substantial amount but also avoids delay in attending the breakdowns.

Following routine checks should be undertaken:-

- 1) As has already been stated in the installation chapter, nuts and bolts etc. fixing the pump on the permanent base-frame should be periodically checked to enable the pump sets to perform efficiently.
- 2) As the pumps sets in RLI Schemes of this Department are operated in most unfavorable condition i.e. in certain chases in dusty conditions even, the lubricating oil of the sump should be replaced after every 200 / 300 hours of operation and the sump should be thoroughly cleaned before fresh lubricating oil is poured in. There is a dip-stick to ascertain the quantum of oil in the sump which should be checked every day and if necessary required quantum of make-up oil is to be added.
- 3) As in most cases, polythene pipes are used for leading oil from tank to filter this should be periodically checked and if necessary these pipes should be replaced, which is not a costly item.
- 4) Overall condition of the engine should be periodically checked by competent mechanic to redress any small matters before major break down occurs. Symptoms of such defects are visible in the trained eye and as such specific remedies cannot be spelt out.
- 5) The stuffing box provided in the back-side of the pump should be checked, at least fortnightly to see the condition of the gland packing. The gland packing should not be excessive tightened, on the contrary, it should be tightened in such manner so that little amount of water oozes out from the stuffing box.
- 6) In the event of detection of low discharge from the pump both the condition of engine and the pump should be checked and of the condition of the engine is alright then the pump should be dismantled and if necessary required corrective measures should be undertaken. But this should not be done in the mid-working season, on the contrary, before commencement of actual working season the pump sets should be properly attended to. In most cases, the wearing ring provided on the periphery of the impeller and on the body of the volute casing requires replacement to prevent damage of the main pump body, which is a costly proposition.
- 7) For repair of both engines and pumps spares of genuine make and quality should only be used for better performance of the pump sets, otherwise frequent breakdown may occur and this will severely affect the irrigation performance of the schemes during actual working season. This is all the more necessary as suitable trained hands are not available in many Divisions / Sub-Divisions.

Very recently the Department has initiated a process for procurement of all vital spares of good quality centrally through Resources Circle. For other items of the specifications etc. of the spares should be properly drawn up and quality assurance programme should be introduced.

## Chapter —V DESIGN OF PIPELINE

### 5.10 Design of P.V.C. Pipeline of R.L.I. Scheme

**PUMP UNIT :** The R.L.I. would be equipped with two 200 m<sup>3</sup> / hr. electric motor powered Centrifugal pumps. Ancillary equipments would include a star-delta starter relay, a low voltage or temperature cut-out, and a capacitor for pump motor protection and a totalizing electric hour meter to monitor operation of pump. The suction pipe would be of mild steel or flexible house pipe and would be provided with a foot valve. The delivery pipe to the primary distribution chamber would be of mild steel.

**PUMP HOUSE :** The Pump House is a brick built structure with concrete floor and R.C.C. Roof. The pump house has a floor area of about 19.26 m<sup>2</sup> with 1.20 m. wide verandah. Switchgear and ancillary electrical devices would be built into the pump house.

**ELEVATED DISTRIBUTION CHAMBERS:** The principles by which distribution chambers would work are similar to that described for HDTW. However, due to size of flow, area command and the number of Sub-systems there would be (1) a Primary Distribution chamber near the pumps and (2) one or more Secondary Distribution chamber located at Strategic points in the Command Area. The actual number of secondary Distribution Chambers would vary with the geometry of Command area.

**(a) PRIMARY DISTRIBUTION CHAMBER:** The desired rate of delivery to each Sub-Command area has been taken as 67 m<sup>3</sup> / hr. which mean that the discharge from a RLI needs to be divided into six streams of approximately that amount. The primary distribution chamber would be located near the pump house and would receive the entire discharge of 400 m<sup>3</sup> / hr. from the RLI pumps to divide the water into six equal streams for serving the sub-command areas and feeding the Secondary Distribution chambers through buried pipe distribution system.

The primary distribution chamber would be a elevated R.C.C. walled chamber of 3.85 m. high from ground and it is constructed on thick R.C.C. base. There would be a number of outlets connected to stand pipes for supplying water to the outlet valves of spout chamber and feeding the Secondary distribution chambers. Just below the outlets there is one precast slab and there would be six rectangular weirs fitted over precast R.C.C. slabs. The diameter of outlet and stand pipe connected to the buried distribution system for serving Sub-Command area would be 200 mm and the diameter of outlet and stand pipe for feeding the Secondary distribution chamber would be about 300 mm or more. The primary distribution chamber would be fitted with a electrical probe which shuts the pump when the water level in the chamber rises to an upper limit owing to the closure of the outlet valves.

**(b) SECONDARY DISTRIBUTION CHAMBER:** The Secondary Distribution Chamber is similar in design to the Distribution Chamber provided for HDTW system except that there would not be any electrical probe which shuts the pump.

**Buried pipe distribution system:** The Command areas of about 80 ha. For R.L.I.'S would be divided into six near-equal sub-areas 13.34 ha. Each and each sub-area being supplied with a separate buried loop or branching system depending upon the geometric shape of the area. The water available in loop or branch would be about 67 m<sup>3</sup> / hr. There would be about 5 to 6 outlets in each loop or branch to serve all field plots within the spout command area. The area served by each spout would be about 2-3 ha. and not plot being farther than 100 m. from the spout chamber. The outlet valve discharges to the spout chamber from which the flow is delivered to the field channels. Each closed loop would be connected to the stand pipe by a short run called lead line, which would be of 200 mm. or 160 mm. dia pipe and the closed loop would be of 140 mm. dia PVC pipe and the closed loop would be of 140 mm dia. PVC pipe. Each branch line would be of 200 mm dia. PVC pipe. The feeder line connecting the Secondary distribution chamber to the Primary Distribution Chamber would of 300 mm. or more PVC or RCC pipe depending upon the volume of flow. The layout sketch of buried pipe distribution system is shown at Sketch- 4.

**DESIGN PROCEDURE FOR BURIED PIPE LINE.**

The design procedure of buried pipe line systems for R.L.I. would be similar to that of HDTW system except that the Command area being large, the distribution of water to the command area would be made from Primary Distribution Chamber as well as Secondary Distribution Chambers located at strategic points within the Command area.

The command area would be divided into six-near equal Sub-Command areas of 13.34 ha. Each and each Sub-Command area would be served by a separate by a separate closed loop or branch. A typical layout of a buried pipe distribution system for RLI along with the design calculation given in Sketch- 4.

The command area is 72 ha. Which has been divided into six near equal sub-command of 12 ha. Each. Three is one Primary distribution chamber at 'a' and two secondary distribution chambers located at 'b' and 'h'. The Sub-Command areas as marked A, B, E, and F have been provided with closed loop system and Sub-command areas as marked C and D with Branching system. The locations of the spout chambers in loop and branch are shown.

The flow of water in each loop or branch : 19 L.P.S.

**TABLE**

Particulars of Pipe Line	Sub Command Area	Length (M)	Flow in (LPS)	Length considered for calculating Head Loss (M)	Diam. of pipe Used in (MM)	Frictional Head Loss in (M/M)	Head Loss in each line (M)	Total Head Loss in (M)
(1)	(2)	(3)	(4)	(5)	(6)	(7)	(8)	(9)
Lead Line	A	100.00	19.0	100.00	160.00 (PVC)	0.005	0.50	1.79
Closed Loop	A	890.00	9.5	445.00	140.00 (PVC)	0.0029	1.29	
Lead Line	B	60.00	19.0	60.00	160.00	0.005	0.30	1.43

Closed Loop	B	780.00	9.5	390.00	(PVC) 140.00 (PVC)	0.0079	1.13	
Branching	C	be=400.0	19.0	400.00	200.00 (PVC)	0.0018	0.72	1.39
Feeder Line	C	ab=420.0	38.0	420.00	300.00 (RCC)	0.0016	0.67	
Branching	D	be=140.0 cd=560.0 700.0	19.0	700.00	200.00 (PVC)	0.0018	1.26	1.93
Feeder Line	D	ab=420.0	38.0	420.00	300.00 (RCC)	0.0016	0.67	
Lead Line	E	30.0	19.00	30.0	160.0	0.005	0.15	2.05
Closed Loop	E	800.0	19.0	400.00	140.0 (PVC)	0.0029	1.16	
Feeder Line	E	ah=460.0	38.0	460.0	300.00 (RCC)	0.0016	0.74	
Lead Line	F	190.0	19.00	190.0	200.0 (PVC)	0.0018	0.35	2.20
Closed Loop	F	770.0	9.50	385.0	140.0 (PVC)	0.0029	1.12	
Feeder Line	F	ah=460.0	38.0	460.0	300.00 (RCC)	0.0016	0.74	

The Total Head loss calculated in Column.(9) is with respect to the elevation of the outlet of Primary Distribution Chamber, which is 3.00 M high above ground level of Primary Distribution Chamber.

The available Head at Primary Distribution Chamber:	3.0 M
Head loss of structure & valves etc.:	(-) 0.30 M.
Elevation of outlet valve (0.50 m. above G.L.):	(-) 0.50 M.
Operating Head Available:	<u>2.20 M.</u>

The total Head loss in pipe line for each Sub-command area being within the operating head the design is safe.

## 5.2 DESIGN OF P.V.C. PIPELINE OF H.D.T.W.

The Command area of 40 ha for HDTW would be divided into three near equal sub areas each of approximately 13.34 ha and each being supplied by a separate buried loop or branching pipe line system. The water available in each loop or branching pipe line would be about 67 m<sup>3</sup> / ha, which would serve about 13.34 ha. There would be about 5 to 6 outlets (spouts) in each loop or branching to serve all points in the Command area. The area served by each outlet (spout) would average approximately 2 to 3 ha and no plot generally being farther than 100 m. from the spout. The outlet valve discharges to the outlet (spout chamber) from which water is delivered to field via field channel systems.

The following criteria are of special importance in the design of buried pipe line system.



(a) The stream flow of 67 m<sup>3</sup> / ha. Is the desirable rate of delivery to the individual cultivator and the flow is taken in rotation among cultivators within 13.34 ha. Area by each pipe line but always at a single point at any time.

(b) Buried pipe can be aligned with complete freedom as far as right-of-way and topographic features are concerned.

(c) Outlet valves can be provided wherever desired in the pipe line as determined in the interest of minimizing distances from the outlet to the field, the number of cultivators served by a particular outlet; and also ensuring gravity, flow from outlet, to the field.

Under the above circumstances two possible types of pipe lay out may be considered. One is the loop system, and other is the branching system. Where the shape of the well command permits, the closed loop system and reduction of flow velocities and head loss in a pipe line. The pipe diameter required in a branching system is an average, about 30% greater than the loop system. But there may be cases, where the branching system cannot be avoided due to shape of the command area.

For HDTW, the pipe line with closed loop distribution system consists of three loops of 140 mm dia PVC pipe each connected to the distribution chamber stand pipe by a short run of 200 mm or 160 mm dia PVC which is known as lead pipe line. For each loop the average length of lead line would be about 325 m. and loop line would be about 615 m.

For pipe line with branching distribution system the dia of PVC pipe would be 200 mm. The PVC pipe is of 2.50 Kg. / Cm<sup>2</sup> working pressure capacity or 25 m. of hydraulic head.

There are three features of the buried pipe lay out which are as follows:-

- (1) There are no air valve since each outlet valve can act as an air release valve if required during initial falling of the line.
- (2) There is only one range riser / vent located near the outer end of the loop.
- (3) The line is designed to remain full at all times without the possibility of gravity drainage.

### **DESIGN PROCEDURE FOR BURIED PIPE LINE:**

As discussed earlier the distribution of water to the field plots within the command area would be made from the distribution chamber through buried pipe line distribution area would be made from the distribution chamber through buried pipe line distribution system, outlet chambers and earthen field channels. For HDTW the command area is about 40 ha and command area would be divided into 3 near-equal sub-areas of 13.34 ha. Each. Each sub-area would be served either by a closed loop or a branching system connected to the stand pipe of distribution chamber by a short run of P.V.C. pipe designated as lead line. If the shape of the sub-area permits it is preferable to use closed loop and otherwise the branching system may be used.

The discharge available from HDTW is  $200 \text{ m}^3 / \text{hr}$ , and discharge available in each loop or branching would be about  $67 \text{ m}^3 / \text{hr}$ . or about  $18.6 \text{ litres} / \text{sec}$ . For the purpose of design the water available in each loop has been taken as  $19 \text{ litres per second}$ .

The following steps are of special importance in designing the pipe line distribution system:-

- STEP — 1** For each H.D.T.W. Scheme prepare a contour map with contour interval of 30 cm or with suitable contour interval on the 16 inches to a mile mouza map showing the boundaries of Command area, Sub-Command areas, and another relevant features, like village, forest, etc.
- STEP — 2** On the plan locate the water point position of Distribution Chamber which would be near to the water point and the distance of each sub-area would not be too large from the distribution chamber.
- STEP — 3** Select the type of pipe layout of each sub-area, which may be either closed loop type or branching type upon the Geometric shape of the command.
- STEP — 4** On the plan draw the alignment of the pipe line clearly showing the lead line, and loop or branching, location of outlet valves, outlet command and field channels taking into consideration that the distance of the remotest field plot within outlet command would be about 100 m. from the outlet valve and water can flow by gravity. Measure the length of the loop / branching and lead line.
- STEP — 5** Design the pipe line as per procedure described below:-
- The outlets of the Distribution Chamber are connected to the pipe distribution system and the elevation of the said outlets are at a height of 3 m. from the G.L. The max. Head available would be guided by the operation head available at stand pipe of the distribution chamber after making in account of the frictional head losses in pipe line and the elevation of the outlet valve.

The figure shown at Sketch 4 is a layout of closed loop system. The flow available at stand pipe is 19.0 Lps. Let length of lead line AB = 120 m. The flow of water through lead line AB would be 19.0 Lps., which would be divided equally at B into two stream of 9.5 Lps. each flowing through each branch of the loop.

	Elevation of outlet of Distribution chamber: $(100.0+3.0)$	=	103.00 M
(a)	Elevation at outlet valve : $(100.0 + 0.5)$	=	(-) <u>100.50 M</u>
			2.50 M
(b)	<u>Losses at structure and valves, say</u>	(-)	<u>0.30 M</u>
	Operating head available :		2.20 M

The operating head available against pipe frictional losses between A and B in the lead line and between B and C on the loop together would be 2.20 m. Maximum length of each loop with 140 mm O.D. PVC Pipe (working pressure =  $2.5 \text{ kg/cm}^2$ ) having 200 mm. O.D. PVC pipe in the lead line may be calculated as below:-

Lead line 120.0 m. of 200 mm. O.D. PVC Pipe Flow Q = 19.0 Lps.

Frictional loss between loss = 0.0018 M/M

Frictional loss between A & B :  $120 \times 0.0018$  = 0.216 M

Head available for loop. :  $(2.20 - 0.216)$  = 1.984 M

Use 140 mm. dia PVC pipe loop.

Flow Q = 9.5 Lps.

Frictional head loss : = 0.0029 M/M

Length of Loop : LM

$\therefore L/2 \times 0.0029 = 1.984$  M

L = 1368 Metres.

Thus Max. length of Loop would not exceed 1368 m. to get a discharge of 19.00 Lps from the outlet located at C.

**Branching system:-** Sometimes the geometric shape of the sub-command area may require branching layout in place of loop layout system. The maximum length of each branching for a particular diameter of PVC pipe may be calculated.

[Reference sketch 4]

A typical layout of a branching systems detailed above. Let. the Ground levels, at A,F,G,C,H and K are 100.00, 100.20, 100.25, 100.00, 100.50 and 99.80 respectively. Maximum permissible length of pipe line for each outlet can be calculated as follows:-

Discharge Q : 19.00 Lps

R.L. of G.L. at A : 100.00 M

Elevation at outlet of Distribution Chamber =  $(100.00 + 3.00) = 103.00$  M

**For outlet no. (1)**

Ground level at outlet No. 1 : 100.20 M

Elevation of outlet valve :  $(100.20 + 0.50) = 100.70$  M

Difference of Elevation between outlet of distribution chamber and outlet valve :  $(103.00 - 100.70) = 2.30$  M.

Assume losses at

structure and valves. = 0.30 M.

The available head against the frictional loss for the

Pipe line (AB + BF) =  $(2.30 - 0.30) = 2$  M.

Use 200 mm dia. PVC pipe

The Frictional head loss : 0.0018 M/M

Maximum permissible length of pipe line

$(AB + BF) = 2 / 0.0018 = 1111.1$  M.

**For outlet No. (5)**

G.L. at outlet valve : (99.80 + 0.50) = 100.30 M

Elevation of outlet valve : (99.80 + 0.50)

Difference of elevation between outlet of distribution

chamber and outlet valve : (103.0 – 100.30) = 2.70 M.

Assume Losses in Structure and valves : 0.30 M.

The available operating head against frictional Loss

For the pipe line (AB + BC + CD + DE + EK) = (2.70 – 0.30) = 2.40 M.

Use 200 mm dia. PVC.

The Frictional head loss = 0.0018 M/M

Maximum permissible length of pipeline

(AB + BC + CD + DE + EK) = 2.40 / 0.0018 = 1333.33 Metres.

Similarly the maximum length of pipeline for other outlets can be calculated.

A typical layout of buried pipe distribution system of a HDTW along is shown in Sketch- 5.

The command area is 39 ha. And the command area has been divided into three near equal Sub-command areas of 13 ha. Each. Considering geometry of the Sub-command areas, the Sub-command areas marked as I and II have been provided with closed Loop distribution system. The position of Tube well and Distribution Chamber etc. are shown in drawing.

The design calculations are shown in table below.

**TABLE**

Particulars of Pipe Line	Sub-command area	Length (M)	Flow in (LPS)	Length considered for calculating Head loss (M)	Diam. of Pipe used in (mm)	Frictional Headloss in (M/M)	Head Loss in each line (M)	Total Head Loss in (M)
1	2	3	4	5	6	7	8	9
Lead Line	I	168.0	19.0	168.0	200.00 (P.V.C.)	0.0018	0.31	
Closed Loop	I	732.0	9.50	366.0	140.00 (P.V.C.)	0.0029	1.062	1.372
Lead Line	II	76.0	19.0	76.0	200.00 (P.V.C.)	0.0018	0.137	
Closed Loop	II	808.0	9.50	404.0	140.00 (P.V.C.)	0.0029	1.172	1.309
Branching	III	701.0	19.0	101.0	200.00 (P.V.C.)	0.0018	1.27	1.27

The total Head loss calculated in Column. (9) is with respect to the elevation of the outlet of Distribution Chamber which is at a height of 3 M. from the Ground level of Distribution Chamber.

The available Head at Primary Distribution Chamber :	3.0 M.
Head loss of structure & valves etc. :	(-) 0.30 M.
Elevation of outlet valves (0.50 m. above G.L.)	(-) <u>0.50 M.</u>
Operating Head available :	2.20 M.

The total Head loss in pipe line for each Sub-command area being less than the operating head the design is safe.

**OUTLET CHAMBER:** The outlet chamber or spout chamber is the link between the buried pipe and the field channels. There would be about six outlet chambers in each loop or branching serving about 2-3 ha. by each outlet chamber. The chamber would be provided with one Alfalfa type valve.

Khadya Bhavan, 6<sup>th</sup> Floor, Block-B,  
11A, Mirza Galib Street,  
Kolkata - 700087.



[ Debdatta Datta ]  
Chief Engineer – II, WRDD  
&

Chairman of Schedule Revision Committee

# **Chapter - VI**

## **SCHEDULE OF RATES**

# 1.00 DRILLING OF TUBEWELLS

## 1.10 Heavy Duty Tubewell of size 350 mm X 200 mm NB

It. No.	Description of item	Unit	Basic Price in Rs
1	Drilling of bore hole 55.88 cm dia through any kind of soil by adopting any method of drilling (by Direct or Reverse Circulation Rotary Rig) upto required depth including digging trenches and pits etc. all complete.		
	(i) Upto 30 metres below G.L.	Metre	1,169.26
	(ii) beyond 30 metres and upto 60 metres.	Metre	1,159.83
	(iii) beyond 60 metres and upto 90 metres	Metre	1,178.69
	(iv) beyond 90 metres and upto 120 metres	Metre	1,197.55
	(v) beyond 120 metres and upto 150 metres	Metre	1,206.98
	(vi) beyond 150 metres and upto 175 metres	Metre	1,272.98
	(vii) beyond 175 metres and upto 200 metres	Metre	1,310.70
	(viii) beyond 200 metres and upto 225 metres	Metre	1,376.71
	(ix) beyond 225 metres and upto 250 metres	Metre	1,414.43
<p>N.B. :- (a) The rates are inclusive of all reaming operations in case of Direct Circulation Rig. Pilot boring drill bit should not be more than 215 mm, in case of Direct Circulation Rotary Rig. In case of Reverse Circulation Rotary Rig the rates should be reduced by 20%.</p> <p>(b) For Siliguri Sub-Divn./ Alipurduar Sub-Division/ Malbazar Sub-Division / Chopra Block (under Uttar Dinajpur District) / Birbhum District / Purulia District / Bankura District / Paschim Medinipur District (except Ghatal, Daspur I &amp; II Block), the above rates shall be enhanced by 10%.</p> <p>(c) In case the bore hole is decided to be abandoned by the competent authority due to non-availability of suitable thickness of aquifer capable of yielding desired discharge, the payment for abandoned bore hole shall be made (i) at 100% of the rates in case of drilling by Reverse Circulation Rig, that is at the rate 80% of the above rate and (ii) at 50% of the rates in case of drilling by Direct Circulation Rig.</p> <p>(d) Measurement will be taken below ground level taking ground level as zero for payment.</p>			
2	Labour charges for lowering of M.S. E.R.W. pipes, strainers, blank pipe etc. and fitting, fixing and jointing of tubewell assembly at sites by welding etc. as per direction of the Engineer-in-Charge.		
	(i) 200 mm NB Blank pipe, Slotted pipe & Bottom Plug	Metre	235.74
	(ii) 350 mm NB Housing pipe	Metre	518.62
N.B.:- For lowering of PVC-U pipes rates for the item no. 2.(i) & 2.(ii) are to be reduced by 30%			
3	Supplying, fitting, fixing including fabrication (IS -2800 Part -I with latest amendments) with required materials as directed by the Engineer-in-charge and lowering in position etc.		
	(i) 10 mm. thick (350 mm x 200 mm) NB M.S. Reducer of approved quality including socket.	Each	3754.83
	(ii) M.S. Centre guide (consisting of 3 nos., 6 mm thick, 50 mm wide, not less than 600 mm long and 125 mm rise of arch) of approved quality.	Each	231.02
	(iii) M.S. Top cap of suitable size (8 mm thick) and approved quality for covering top of housing pipe of 350 mm NB (Top cap will be tack welded with housing pipe at 4 points 90° apart).	Each	1073.08
	(iv) 100 mm width x 12 mm thick Sockets / Rings made from MS Flats by rolling process and double butt welding for joining 350 mm NB Housing Pipe.	Each	721.36
	(v) 75 mm width x 10 mm thick Sockets / Rings made form MS Flats by rolling process and double butt welding for joining 200 mm NB Pipe.	Each	429.04
4	Supply of gravel for use as pack in tube well of 2 mm to 4 mm. size (as per IS: 4097) and gravel treatment of tubewell including screening, washing, cleaning etc. of the gravels at the site, all complete as per direction of the Engineer-in-Charge.		
	i) For sites within 4 Km. from all weather metal road	Cu.M.	2044.32
	ii) For sites upto any distance beyond 4 Km. From all weather metal road	Cu.M.	2227.25

It. No.	Description of item	Unit	Basic Price in Rs
5	Development of tubewell in accordance with IS: 2800 (part 1) and IS: 11189 to establish maximum rate of usable water yield without sand content beyond permissible limit with required capacity of compressor ( about 200 psi, 375 cfm Aircompressor, actual psi and cfm depend on tube well head conditions), running the compressor for required time till well is fully developed and followed by development of tube well by over pumping with 15% to 25% higher discharge than expected discharge of tube well capacity and Vertical Trubine pump and carrying out step-drawdown test, yield test, verticality test etc. as per prescribed method all complete including hire & labour charges of compressor, tools & accessories etc. all as per requirement and direction of Engineer -In - Charge.		
	(i) Depth upto 120 metre.	Each tubewell	31711.41
	(ii) Depth beyond 120 metre and upto 200 metre.	Each tubewell	38717.53
	(iii) Depth beyond 200 metre.	Each tubewell	44648.68
6	Making slots of 75 mm X 1.60 mm size with a minimum clearance of 4.70 mm in between two adjacent slots over the outer surface of 200 mm NB ERW pipes (to be issued departmentally) in 10 (ten) rows (each row consisting of 96 slots) per metre length of ERW pipe with a clearance of 25 mm in between two rows as per drawing and specification including smoothening the edges after slotting, cost of transportation of ERW pipes from Departmental Store to Workshop and back to drilling site, loading, unloading and carrying by head-load where necessary both ways, all complete.	Metre	754.36
7	Mobilisation charges for transporting upto site including loading, unloading of all plants, machinaries and equipments required for drilling, development and testing of Tubewells and also the cost of construction of temporary roads over field and / or, culverts, repairing existing roads and / or culverts all complete, carrying materials on head load, carts or boats as the case may be :-		
	(i) For sites within 4 km from all weather metal road.	Each	7625.64
	(ii) For sites up to any distance beyond 4 km from all weather metal road.	Each	15251.27



## 1.20 Medium Duty Tubewell of size 250 mm X 150 mm NB

It. No.	Description of item	Unit	Basic Price in Rs
1	(a) Drilling of bore hole 45.72 cm dia through any kind of soil by adopting any method of drilling (direct or reverse circulation rotary) upto required depth including digging trenches and pits etc. all complete.		
	(i) Upto 30 metre below G.L.	Metre	1056.10
	(ii) beyond 30 metres and upto 60 metres.	Metre	1046.67
	(iii) beyond 60 metres and upto 90 metres.	Metre	1065.53
	(iv) beyond 90 metres and upto 120 metres.	Metre	1074.96
	(v) beyond 120 metres and upto 150 metres.	Metre	1084.39
	(vi) beyond 150 metres and upto 175 metres.	Metre	1188.12
	(vii) beyond 175 metres and upto 200 metres.	Metre	1225.84
	(viii) beyond 200 metres and upto 225 metres.	Metre	1282.41
	(ix) beyond 225 metres and upto 250 metres.	Metre	1301.27
<p><b>N.B. :-</b> (a) The rates are inclusive of all reaming operations in case of Direct Circulation Rig. Pilot boring drill bit should not be more than 215 mm, in case of Direct Circulation Rotary Rig. In case of Reverse Circulation Rotary Rig the rates should be reduced by 20%.</p> <p>(b) For Siliguri Sub-Divn./ Alipurduar Sub-Division/ Malbazar Sub-Division /Chopra Block (under Uttar Dinajpur District) / Birbhum District/ Purulia District/ Bankura District / Paschim Medinipur District (except Ghatal, Daspur I &amp; II Block), the above rates shall be enhanced by 10%.</p> <p>(c) In case the bore hole is decided to be abandoned by the competent authority due to non-availability of suitable thickness of aquifer capable of yielding desired discharge, the payment for abandoned bore hole shall be made (i) at 100% of the rates in case of drilling by Reverse Circulation Rig, that is at the rate 80% of the above rate and (ii) at 50% of the rates in case of drilling by Direct Circulation Rig.</p> <p>(d) Measurement will be taken below ground level taking ground level as zero for payment.</p>			
2	Labour charges for lowering of M.S. E.R.W. pipes, strainers, blank pipe etc. and fitting, fixing and jointing of tubewell assembly at sites by threading, welding etc. as per direction of the Engineer-in-Charge.		
	(i) 150 mm NB Blank pipe, Slotted pipe and Bottom Plug	Metre	207.45
	(ii) 250 mm NB Housing pipe	Metre	424.33
<p><b>N.B. :-</b> For lowering of UPVC pipe rates for the itemNo. 2(i) &amp; 2(ii) are to be reduced by 30%</p>			
3	(a) Supplying, fitting, fixing including fabrication (IS -2800 Part - I with latest amendments) with required materials as directed by the Engineer-in-charge and lowering in position etc.		
	(i) 8 mm thick (250mm × 150mm) M.S. NB Reducer of approved quality including socket	Each	3218.29
	(ii) M.S. Centre guide (consisting of 3 nos., 6 mm thick, 50 mm wide, not less than 600 mm long and 125 mm rise of arch) of approved quality.	Each	231.02
	(iii) M.S. Top cap of suitable size (6 mm thick) and approved quality for covering top of housing pipe of 250 mm NB (Top cap will be tack welded with housing pipe at 4 points 90° apart).	Each	901.46
	(iv) 100 mm width × 12 mm thick Sockets / Rings made from MS Flats by rolling process and double butt welding for joining 250 mm NB Pipe.	Each	571.43
	(v) 75 mm width × 10 mm thick Sockets / Rings made from MS Flats by rolling process and double butt welding for joining 150 mm NB Pipe.	Each	343.23
	(b) Supplying, fitting, fixing the following fittings of PVC-U conforming to IS: 12818 & lowering in position etc. as directed by the Engineer-in-Charge		
	(i) 250 mm x 150 mm reducer consisting of two nos. of reducer 250 x 200 mm & 200 x 150 mm PVC-U taper shaped reducing socket with inner thread for larger end & outer thread for smaller end.	Each	3300.33
	(ii) M.S. Centre guide (consisting of 3 nos., not less than 450 mm long and 125 mm rise of arch) of approved quality with two nos. MS clamps suitable for PVC-U pipes.	Each	235.74
	(iii) 150 mm DN PVC-U end cap.	Each	273.46
(iv) 250 mm DN PVC-U top cap.	Each	532.77	

It. No.	Description of item	Unit	Basic Price in Rs
4	Supply of gravel for use as pack in tube well of 2 mm to 4 mm. size (as per IS: 4097) and gravel treatment of tubewell including screening, washing, cleaning etc. of the gravels at the site, all complete as per direction of the Engineer-in-Charge		
	i) For sites within 4 Km. from all weather metal road.	Cu.M.	2044.32
	ii) For sites upto any distance beyond 4 Km. from all weather metal road.	Cu.M.	2227.25
5	Development of tubewell in accordance with IS: 2800 (part 1) and IS: 11189 to establish maximum rate of usable water yield without sand content beyond permissible limit with required capacity of compressor ( about 150 psi, 300 cfm Aircompressor, actual psi and cfm depend upon tube well head conditions), running the compressor for required time till well is fully developed and followed by development of tube well by over puming with 15% to 25% higher discharge than expected discharge of tube well capacity Vertical Trubine pump and carrying out step-drawdown test, yield test, verticality test etc. as per prescribed method all complete including hire & labour charges of compressor, tools & accessories etc. all as per requirement and direction of Engineer -in - Charge.		
	(i) Depth upto 120 metre	Each tubewell	26231.93
	(ii) Depth beyond 120 metre and upto 200 metre.	Each tubewell	30645.88
	(iii) Depth beyond 200 metres.	Each tubewell	36445.02
6	Making slots of 75 mm × 1.60 mm size with a minimum clearance of 4.70 mm in between two adjacent slots over the outer surface of 150 mm nominal bore ERW pipe (to be issued departmentally) in 10 (ten) rows (each row consisting of 64 slots) per metre length of ERW pipe with a clearance of 25 mm in between two rows as per drawing and specification including smoothening the edges after slotting, cost of transportation of ERW pipes from Departmental store to Workshop and back to drilling site, loading, unloading and carrying by head-load where necessary both ways, all complete.	Metre	555.40
7	Mobilisation charges for transporting upto site including loading, unloading of all plants, machinaries & equipments required for drilling, development and testing of Tubewells and also the cost of construction temporary roads over field and / or culverts, repairing existing roads and / or culverts all complete, carrying materials on head load, carts or boats as the case may be :-		
	(i) For sites within 4 km from all weather metal road.	Each	7625.64
	(ii) For sites up to any distance beyond 4 km from all weather metal road.	Each	15251.27



It. No.	Description of item	Unit	Basic Price in Rs
6	Electrologging of bore hole of different dia tubewell for locating water bearing strata and saline aquifer, if any, after conducting relevant geophysical tests. All test reports, compiled data and raw data sheets should be submitted to the Engineer-in-Charge (Cost is inclusive of all charges for equipments, labour, data aquisition & compilation of data sheets as per direction of the Engineer-in-charge)	Each Tube-well	8015.08
7	Conducting geophysical survey for ground water potentiality and to evaluate the layer parameters in terms of depth by surface resistivity technique adopting Vertical Electrical Sounding (VES) method for locating pin pointed location of tube well including charges for instruments & transportation thereof and services all complete at site and submission of data collected from each site for analysis (For each site at least 3 nos. location are to be surveyed).		
	a) for depth upto 150 metres from G.L.	Each Set	1697.31
	b) for depth greater than 150 metres upto 200 metres	Each Set	1885.90
	c) for depth greater than 200 metres	Each Set	2357.38
8	Interpretation of VES data including analysis of data & interpretation of layer parameters and submission of report including expected yeild.	Each Set	942.95
9	Drilling of bore holes by a suitable Down The Hole (DTH) cum mud rotary combination rig with foam and mud drilling including collection of lithological surplus with maintaining the time log for drilling through different strata as directed by the Engineer in Charge.		
	a) Drilling of 250 mm dia. borehole suitable for lowering 200 mm internal dia, casing pipe lowering through overburdens of clay / consolidated moorum / consolidated laterite / fragmented granite etc. formation including overburden upto 1 metre beyond depth of overburden.	Metre	320.60
	b) Drilling of 165 mm dia. through fissure, consolidated hard rock strata with necessary valve hammer and with necessary air pressure from beyond 1 metre overburden to 200m below G.L.	Metre	1008.96
10	Drilling of bore hole in DTH process through any kind of soil and rocks in overburden suitable for lowering & fitting, fixing of 125 mm internal dia. Casing pipe (Departmental supply) upto 1 metre depth beyond overburden and subsiquently 115 mm dia. boring through any kind of rocky formation upto a total depth of 50 metres in case of dry drilling may be extended upto 75 metres including all other works necessary for boring as per direction of E.I.C. (Rates are inclusive of all materials necessary for drilling works).		
	a) For depth upto 50 metre	Metre	386.61
	b) From 50 metre to 75 metre and above	Metre	400.75
11	Development of tubewell with high velocity jetting tool combined with adequate capacity Air-compressor and carrying out yield test, as per prescribed method with report suggesting placement of pump (type + yield) after obtaining sediment and colour free water as per direction of the Engineer-in-Charge, including arranging, installing all equipments and testing instruments as required at site and dismantling the same after successful completion of tests, all complete.		
	For 150 mm N.B/D.N slotted / screen pipes upto 18 metre length.	Each Tube-well	18896.72
12	Washing and developing of tube well with Air-compressor, pump & engine for not less than 8 hrs. contineous pumping with necessary arrangements for testing the yield in Gallons per hr. including hire and labour charges for all tools & plants etc. all complete. (Applicable for DTH drilling of Item no. 9)	Item	8958.03

**1.40 Light Duty Tubewell of size 150 mm × 80/100 mm Nominal Bore / Nominal Diameter.**

It. No.	Description of item	Unit	Basic Price in Rs
1	Drilling of bore hole of suitable diameter upto required depth by water jet system through any type of soil including hire and labour charges for boring pipes, scaffolding, other tools and plants etc. and taking out the same all complete and other incidental works in this connection. The bore hole should have minimum 65 mm gap in between outside of the tube well pipe and the bore.		
	i) for lowering 80 mm dia GI/PVC pipe	Metre	240.45
	ii) for lowering 100 mm dia GI/PVC pipe	Metre	262.14
	iii) for lowering 150 mm dia GI/PVC pipe	Metre	565.77
	<p>N.B.:- (a) Measurement will be taken below Ground Level taking Ground Level as zero for payment.                      (b) (i) For Siliguri Sub-Divn. / Alipurduar Sub-Division / Malbazar Sub-Division / Jalpaiguri Sub-Division the above rates shall be enhanced by 20%. (ii) Chopra Block (Under Uttar Dinajpur District) / Birbhum District / Purulia District / Bankura District / Paschim Medinipur District (except Ghatal, Daspur I &amp; II Blocks), the above rates shall be enhanced by 10%.                      (c) In case, the bore hole is decided to be abandoned by the competent authority due to non-availability of suitable thickness of aquifer capable of yielding desired discharge, the payment for abandoned bore hole shall be made at the rate indicated against item 1.                      (d) To arrived the cost for boring of a tube well of 80 mm dia with top enlargement of 150 mm dia. of depth 30 meter having a total depth of boring 150 metre from GL e.g. 30 m x 1(iii) + 120 m x 1(i) = 30m x Rs.565.77 + 120m x Rs. 240.45 = Rs.16,973.10 + Rs.28,854.00 =Rs.45,827.10</p>		
2	Labour charges for lowering of pipe, strainers, blank pipe etc. and fitting, fixing the same including cutting, threading where necessary complete including bucket washing and other incidental works in this connection.		
	(i) 80 mm dia G.I. Blank pipe, Bottom Plug with cutter, Brass Jacketted / stainless steel strainer / PVC strainer /screen/slotted pipes .	Metre	70.72
	(ii) 100 mm dia G.I. Blank pipe, Bottom Plug with cutter, Brass Jacketted / stainless steel strainer.	Metre	94.30
	(iii) 150 mm dia. G.I. Housing pipe.	Metre	136.73
	N.B. :- For lowering of PVC-U pipe rates for the item No. 2(i), 2(ii) & 2(iii) are to be reduced by 25%		
3	a) Supplying and filling up of the annular space between the Well Pipe and the bore hole by coarse sand including watering as necessary as per direction of the Engineer-in-Charge.	Cum	718.53
	b) Supply of gravel for use as pack in tube well of 2 mm to 4 mm. size(as per IS: 4097) and gravel treatment of tubewell including screening, washing, cleaning etc. of the gravels at the site, all complete as per direction of the Engineer-in-Charge	Cu.M.	2227.25
4	Supplying, fitting and fixing including supplying of suitable joining compound for fixing in position, threading, if necessary etc. all complete.		
	(a) i) 80 mm. dia. Steel cutter piece upto 450 mm. long with socket.	Each	452.62
	(a) ii) 100 mm. dia. CI cutter piece upto 450 mm. long with socket.	Each	330.03
	(b) i) 80 mm. X 150 mm. M.S. heavy type belmouth reducing socket (6 mm. thick).	Each	744.93
	(b) ii) 100 mm. X 150 mm. M.S. heavy type belmouth reducing socket (6 mm. thick).	Each	754.36
	(c) 150 mm dia G.I. threaded top cap fixed in position.	Each	565.77
	(d) 80 mm dia plug of approved make conforming to I.S. Specifications.	Each	150.87
	(e) (i) 80 mm. X 150 mm. UPVC reducing socket .	Each	433.76
	(e) (ii) 100 mm. X 150 mm. UPVC reducing socket .	Each	471.48
5	Washing and development by pumping with 30 cum per hour capacity pump for a period till sand free water comes out and the discharge is about 30 cum per hour, followed by final yield test; inclusive of all tools, plants and scaffolding and hire charge of submersible pump, generator etc. all complete	Each Tube-well	4563.88

*AM*

It. No.	Description of item	Unit	Basic Price in Rs
6	Charges for Mobilisation of drilling equipments, tools and plants etc. and transportation of departmental materials from Sub-divisional store to work site and returning excess departmental materials if any, to Sub-divisional store after completion of work.	Each Tube-well	1810.46
7	Making arrangement and showing verticality test and sounding test including cost / hire charges of necessary tools and plants, scaffolding, labour etc. all complete as per direction of Engineer-in-Charge.	Each Tubewell	858.08

**1.50 Shallow Tubewell of size 80 mm dia. Fitted with Electrical / Diesel Engine Pump Sets.**

It. No.	Description of item	Unit	Basic Price in Rs
1	Drilling of bore hole of suitable diameter up to required depth for lowering 80 mm diameter G.I. Pipe by water jet system / hand sludge method through any type of soil including hire and labour charges for boring pipes, scaffolding, other tools and plants etc. and taking out same complete. N.B.- (a) Measurement will be taken below Ground Level taking Ground Level as zero for payment. (b) (i) For Siliguri Sub-Divn. / Alipurduar Sub-Division / Malbazar Sub-Division / Jalpaiguri Sub-Division the above rates shall be enhanced by 20%. (ii) Chopra Block (Under Uttar Dinajpur District) / Birbhum District / Purulia District / Bankura District / Paschim Medinipur District (except Ghatal, Daspur I & II Blocks), the above rates shall be enhanced by 10%. (c) In case, the bore hole is decided to be abandoned by the competent authority due to non-availability of requisite thickness of aquifer capable of yielding desired discharge, the payment for abandoned bore hole shall be made at the rate indicated against Item 1.	Metre	155.59
2	(a) Extra over rate of drilling in soil for boring through hard compact clay by rotational hand sludge method including hire and labour charges for boring pipes, scaffolding, other tools and plants etc. and taking out same complete (total boring by this method not to exceed seven metre). (b) Extra over rate of drilling in soil for boring through boulders (Sand stones, etc.) beyond initial 7(seven) metres by combination of hammering and hand sludge method including hire and labour charges for boring pipes, scaffolding, other tools and plants etc. and taking out same complete (total boring by this method not exceeding nine metres)	Metre	179.16
	N.B.- Execution of Item 2(a) & 2(b) shall be limited within the area under laid by Piedmont Zone in Jalpaiguri District except Sadar, Mainaguri and Rajgunj Block; Siliguri Sub-Division and Tufanganj - I & II Block.	Metre	650.64
3	Labour charges for lowering of pipe, strainers, blank pipes etc. and fitting fixing the same including cutting, threading where necessary complete including bucket washing and other incidental works in this connection. (i) 80 mm dia. G.I. Pipe with bottom plug. (ii) 80 mm dia brass jacketted / stainless steel strainer. (iii) 80 mm dia G.I. blank pipe.	Metre	70.72
		Metre	70.72
		Metre	70.72
4	Supplying and filling up of the annular space between the Well Pipe and the bore hole by coarse sand of fineness modulus not less than 2 including watering as necessary as per direction of the Engineer-in-Charge.	Cum	848.66
5	Supplying, fitting and fixing including supplying of suitable joining compound for fixing in position, threading, if necessary etc. all complete. a) 80 mm dia Steel cutter piece upto 450 mm long with socket b) 80 mm dia M.S. threaded top cap fixed in position. c) 80 x 80 x 40 mm dia G.I. Pendent / Bombay Tee d) i) 40 mm dia MAYA hand pump no. 6. d) ii) domestic pump of approved make 40/50 mm dia e) 50 mm long 80 mm dia G.I. nipple. f) 50 mm long 40 mm dia G.I. nipple. g) 250 x 50 x 6 mm thick, 80 mm dia., M.S. Supporting clamp with 2 Nos. 12 mm dia. 65 mm long bolts, nuts, washer, on each side. h) 80 mm dia plug of approved make conforming to I.S. Specifications.	Each	452.62
		Each	103.72
		Each	396.04
		Each	1772.75
		Each	1367.28
		Each	56.58
		Each	37.72
		Set	990.10
		Each	146.16
6	Washing and development by pumping with 30 cum per hour capacity pump for a period till sand free water comes out and the discharge is about 30 cum per hour, followed by final yield test; inclusive of all tools, plants and scaffolding and hire charge of centrifugal pump set and other fittings as necessary all complete.	Each Tubewell	1574.73
7	Supplying 80 mm dia. P.V.C. Hose Pipe of approve make and brand.	Metre	136.73
8	Supplying 80 mm dia. Heavy type Hose clamp.	Set	14.14

It. No.	Description of item	Unit	Basic Price in Rs
9	Supplying 80 mm dia. G.I. Tail Piece suitable for connecting Hose Pipe with Pendent Tee and suction side of pump.	Each	99.01
10	Labour charges for instalation of 5 H.P. Diesel Engine Pump Sets on base plate, including fixing, aligning and connecting the suction side of the pump set with Pendant Tee by Hose Pipe, Hose Clamp and Tail Piece.	Each Tubewell	546.91
11	Labour charges for testing of 5 H.P. Pump set at site for at least 1 (one) hour including supplying necessary fuels and lubricants.	Each Tubewell	556.34
12	Charges for Mobilisation of drilling equipments, tools & plants etc. and transportation of departmental materials from sub- divisional store to work site and returning excess departmental materials if any, to sub-divisional store after completion of work.	Each Tubewell	876.94



**1.60 Performance of Pumping Test ( for evaluation of aquifer parameters)**

It. No.	Description of item	Unit	Basic Price in Rs
1	Hire charge of generators including accessories and operational personnels for aquifer parameter test including transportation, fuel, lubricant, electrical connections etc. complete ( 2 nos generators - one running & one stand by for uninterrupted power supply to be arranged for each site).		
	i) 10 K.V.A	Per Day	4450.72
	ii) 20 K.V.A	Per Day	7590.75
	iii) 30 K.V.A	Per Day	9504.94
2	Hire charges of submersible pump sets of 100 cum/hr capacity, with column pipes, sluice valve, 90° bend, short piece, starter, mainswitch, cable etc. all complete as per instruction of Engineer-in-charge including testing equipments.	Each Site	12654.39
3	Labour charges for lowering the submersible pump set, column pipes with necessary accessories including fitting & fixing the same in the tubewell including proper electrical connection with generator all complete as per direction of Engineer-in-charge and also withdrawal of the same after completion of the test.	Each Site	2470.53
4	Supplying and installing the following materials / furniture etc. including withdrawal of the same the cost of transportation all complete as per direction of Engineer-in-charge.		
	i) Tent ( 8 m x 6 m ) - 2 nos	Each	1150.40
	ii) Tent ( 1.5 m x 1.5 m ) - 4 nos ( for observation well)	Each	330.03
	iii) Table ( 1.2 m x 0.6 m ) - 4 nos	Each	122.58
	iv) Chair - 20 nos.	Each	61.29
5	Making Electrical arrangements in tents & at site including fitting, fixing of 2 Nos. White Metal Light (400W), 1 no. White Metal Light (150W), 2 Nos. Stand Fan, 2 Nos. Tube Light, 2 Nos. CFL Lamps (24W) on hiring basis from the Generator during the total period of the stipulated test as per direction of the Engineer-in-charge .	Per Day	1150.40

## 1.70 PIEZOMETRIC TUBE

It. No.	Description of item	Unit	Basic Price in Rs
1	Withdrawal of 50 mm dia. G.I. Pipe from existing Piezometric Tubes by any means (Measurements will be done as per length of pipe and the rate is inclusive of hire charges of tools and plants). (i) Upto 20 Metres below G. L. (ii) Beyond 20 Metres below G. L.	Metre Metre	Latest PWD Sanitary & Plumbing SOR of Govt. of West Bengal to be followed
2	Withdrawal of 40 mm dia. G.I. Pipe & strainers from existing Piezometric Tubes by any means (i) Upto 20 metres below G.L. (ii) Beyond 20 metres and upto 150 metres below G.L.	Mtr. Mtr.	Do Do
	(Measurement will be done as per length of pipes and strainers, and the rate is inclusive of hire charges of tools and plants).		
3	Supplying, fitting and fixing 50 mm x 40 mm. dia. Heavy type G.I. reducing socket with I.S. Mark.	Each	Do
4	Supplying, fitting and fixing 50 mm. dia. G.I. Top Cap (Internally threaded) with I.S. Mark.	Each	Do
5	Labour charges for boring tube well of required dia. by water jet system through any type of soil strata including hire and labour charges for boring pipes, scaffolding, tools and plants as necessary and taking out them and lowering pipes, strainers, blind pipe etc. and fitting and fixing the same complete including bucket washing and other incidental works in this connection the tube-well should have a minimum 50 mm gap in between the outside of the tube well pipe and bore.		
	(a) 80 mm. dia.	Mtr.	Do
	(b) 50 mm. dia.	Mtr.	Do
	(c) 40 mm. dia.	Mtr.	Do
6	Supplying, fitting & fixing of M.S supporting clamps in two halves of 250 mm x 65 mm x 8 mm size with two (2) nos. of bolt of 12 mm dia, 65 mm long with necessary nuts, washers etc. provided on either side of the clamp i.e. total 4 nos. of bolts with nuts, springs and flat washers for holding & supporting 50/80 mm tube well assembly on concrete block.	Each set	707.21
7	Cleaning and washing of withdrawn G.I. pipes and strainers and other accessories including supply and application of chemicals and stacking the serviceable materials separately as directed. The chemical should be selected and applied as per direction of the Engineer-in-charge. (applicable in case of withdrawal of existing P.tube)		
	i) 80 mm dia.	Mtr.	12.26
	(ii) 50 mm. dia.	Mtr.	11.32
	(iii) 40 mm. dia.	Mtr.	10.37
8	Bucket washing with the help of suitable bucket after applying Chemical treatment including supply of chemical re-agents & necessary labour for this work complete. (Only for repair / washing & cleaning works).	Each	707.21
9	Pumping with hand pump for at least 3 hours till sand free water is available from piezometric tubes including carrying, loading, un-loading & hiring charge of pump etc. complete.		
	i) Hand pump (Shallow well reciprocating pump) when water level is within atmospheric suction limit from GL.	Each	660.07
	ii) Hand pump (Deep well cylinder pump) when water level is beyond atmospheric suction limit from GL.	Each	801.51
10	Charges for Mobilisation of drilling equipments, tools & plants etc. and transportation of departmental materials from sub-divisional store to work site and returning excess departmental materials if any, to sub-divisional store after completion of work for new p-tube, withdrawal & re-sinking etc.	Each Point	707.21

It. No.	Description of item	Unit	Basic Price in Rs
11	Charges for Mobilisation/transportation of tools & plants, chemicals, bucket, hand pump/cylinder etc. for washing & cleaning of existing P-tube all complete.	Each	471.48
12	Washing and development by Air Compressor of adequate capacity for a period of at least 2 hours till sand free water comes out inclusive of hire and transportation charges of all tools & plants as necessary all complete as per direction of EIC. (Applicable for 80 mm or above dia P.Tube with specific permission of Superintending Engineer).	Each	1697.31
13	Cement Concrete (1:2:4) Base Block of (600x600x300mm) for fixing base of P-tube.	Each	754.36
14	Charges for opening & re-fixing the top cap of the Piezometric tube including hire and labour charges for tools & plants as required all complete	Each Site	28.29
15	Charges for opening and re-fixing the hand pump including hire & labour charges for tools & plants as required all complete.	Each Site	56.58
16	Labour charges for measuring water level from P.Tube/ Dug well/ Tube well by water level indicator/ sounding/ tape etc. including hiring & carrying charges of tools etc.	Each	14.14
17	Charges for collection of water sample as per direction in double capped 'Alkathena Bottle' of 500 ml capacity i/c supply thereof and delivery of sample bottle at office.	Each	18.86
18	Supplying, fitting & fixing of steel cutter piece upto 450 mm long with socket		
	i) 40 mmdia	Each	PWDSOR(S&P)
	ii) 50mm dia	Each	PWDSOR(S&P)
	iii) 75 mm dia	Each	PWDSOR(S&P)
19	Supplying, fitting & fixing of plug of approved make conforming to I.S. specification.		
	i) 40 mmdia	Each	PWDSOR(S&P)
	ii) 50mm dia	Each	PWDSOR(S&P)
	iii) 75 mm dia	Each	PWDSOR(S&P)

<b>2.00 LAYING OF PIPELINE</b>			
<b>It. No.</b>	<b>Description of item</b>	<b>Unit</b>	<b>Basic Price in Rs</b>
<b>2.10 EARTH WORK FOR PIPE LINE</b>			
1	Earth work in excavation of field trenches as per design section and alignment for laying of pipe lines (PVC, RCC, ACP etc.) upto a depth of 1500 mm all sorts of soils including removing, spreading or stacking extra earth as directed. The item includes necessary trimming of sides trenches, levelling, dressing and ramming the bottom as required complete	Cum	99.01
2	Earth work in filling in trenches after laying pipe lines (PVC, RCC, ACP etc.) with good earth obtained from excavation of field trenches in layers not exceeding 225 mm, including watering and ramming etc. layer by layer complete. (Payment will be made on the basis of measurement of finished quantity of work.)	Cum	66.01
<b>2.20 LAYING OF P.V.C. PIPE LINE FOR HDTW, MDTW &amp; R.L.I. SCHEMES AND A.C.P. PIPE LINE FOR MDTW AND MINI RLI SCHEMES.</b>			
1(A)	Laying of P.V.C. pipes of different diameters within field trenches in curve / straight line using P.V.C. fittings, viz. Bend, Tee, Reducer etc. and making leak proof joints with couplers after roughening the surface with wire brush and emery paper and applying solvent cement (The rate is inclusive of transport of pipes, fittings and solvent cement to be supplied by Deptt.) all complete as per direction of Engineer-in-Charge. (i) 315 mm dia. (ii) 200 mm dia. (iii) 140 mm dia. (iv) 110 mm dia.	Metre Metre Metre Metre	11.32 10.84 10.14 8.72
1(B)	Laying of Asbestos cement pressure pipes class-10 as per IS : 6530/1972 of different diameters within field trenches in curve/straight line using CI fittings, viz. horizontal or vertical bends, Risers pipes, Tee, Reducers etc. & making leakproof joints within AC Couplings by push & fit method (The rate is inclusive transport of pipes, fittings from sub. divisional stores to the working point, materials will be supplied by department) all complete as per direction of EIC. i) 200 mm dia. ii) 150 mm dia. iii) 125 mm. dia. iv) 100 mm dia.	Metre Metre Metre Metre	15.09 12.49 10.84 8.49
2	Labour Charges for fitting, fixing and laying, where necessary of following M.S / G.I. / E.R.W. pipes and accessories (to be supplied departmentally) including transportation of the same cutting, threading, jointing and making leak-proof threaded / flanged joint at site, by using socket / rubber insertion, nuts and bolts etc. maintaining proper alignment and level - all complete - as per direction of Engineer-in-Charge. (i)(a) 150 mm. dia. ERW pipe. (i)(b) 100 mm dia. NB ERW/MS Pipes (ii) 150 mm X150 mm x 25 mm dia.unequal tee, all ends threaded and fitted with threaded cap on 25 mm. dia.end heavy duty M.S. sockets on other two ends. (iii) 150 mm. dia. M.S. screwed boss flange (iv) 110 mm dia.E.R.W. pipe 90° bend, both ends flanged. (v) 150 mm. dia. ERW pipe 90° return bend, both end flanged including supplying and fixing wooden block (vi) 150 mm. dia. 300 mm. long special type water outer with socket fitted at one end. (vii) 200 mm. dia. 700 mm. long ERW pipe short piece, end to be flanged and welded. (viii) 200 mm. dia. 2330/235 mm.long ERW pipe piece, both end to be flanged and welded. (ix) 200 mm. dia. 525 mm. long ERW pipe short piece, one end to be flanged and welded.	Metre Metre Each Each Each Each Each Each Each Each	134.84 82.51 41.49 27.35 113.15 269.68 54.69 269.68 430.93 243.28

It. No.	Description of item	Unit	Basic Price in Rs
	(x) 200 mm X 200 mm X 200 mm. ERW pipe equal tee with all ends flanged.	Each	134.84
	(xi) 200 mm X 200 mm X150 mm X 40 mm. ERW pipe cross fitted with threaded cap/plug on 40 mm. dia. end and flanged on all other ends.	Each	121.64
	(xii) 150 mm. dia. special bend, both ends flanged.	Each	81.09
	(xiii) 150 mm. dia. Butter Fly valve.	Each	41.49
	(xiv) M.S. rectangular notch plate.	Each	162.19
	(xv) 150 mm. dia. 700 mm. long ERW short piece, one end to be flanged and welded.	Each	243.28
	(xvi) 150 mm. dia. 2330 mm. long ERW pipe short piece, both end to be flanged and welded.	Each	404.53
	(xvii) 150 mm. dia. 525 mm. long ERW pipe short piece, one end to be flanged and welded.	Each	215.94
	(xviii) 150 mm X150 mm X150 mm. ERW pipe equal tee, all ends flanged.	Each	202.73
	(xix) 150 mm X150 mm X150 mm X 25 mm. ERW pipe cross, two ends fitted with 150 mm. dia. M.S. flange, one end fitted with 150 mm. dia. M.S. blank flange and the remaining end fitted with 25 mm.dia. M.S. plug / threaded cap.	Each	108.44
	(xx) 350 mm. dia. C.I. Sluice valve.	Each	81.09
	(xxi) 300 mm. dia. 2250 mm. Long ERW pipe, both end to be flanged and welded.	Each	539.37
	(xxii) 300 mm. dia. 800 mm. Long ERW pipe, one end to be flanged and welded.	Each	323.43
	(xxiii) 300 mm. dia. 600 mm. Long ERW pipe, one end to be flanged and welded.	Each	297.03
	(xxiv) 300 mm. dia. 600 mm. Long ERW pipe, both end to be flanged and welded.	Each	297.03
	(xxv) 300 mm X 300 mm X 300 mm. ERW pipe equal Tee, all end flanged.	Each	188.59
	(xxvi) 300 mm. dia. ERW pipe special bend, both ends flanged.	Each	121.64
	(xxvii) 300 mm X 300 mm X 300 mm X 40 mm. ERW unequal Cross, two ends fitted with 300 mm. dia. M.S. flange, one end fitted with 300mm. dia. M.S. blank flange and remaining end fitted with 40mm. dia. M.S.plug / threaded cap.	Each	148.99
	xxviii) 150mm. dia. C.I. sluice valve.	Each	54.69
	(xxix) 40 mm. dia. 30 cm. long G.I. pipe one end screwed and fitted with M.S. cap.	Each	27.35
3	Labour charges for fitting, fixing 150 mm. Dia. Alfa-Alfa valve with 160mm. dia. P.V.C. riser pipe with the help of flanged P.V.C. tail-piece by joining the P.V.C. End of Tail-piece and riser pipe with coupler and flanged end of Tail-piece and Alfa-Alfa valve with rubber insertion, nuts and bolts etc. complete.	Each	112.21
4	Labour charges for fitting, fixing M.S. Special bend with 160 mm X 200 mm. dia. P.V.C. reducer with the help of flanged tail-piece by joining P.V.C. end of tail-piece and 160 mm. end of reducer with coupler and flanged end of tail-piece and special bend with rubber insertion, nuts and bolts complete.	Each	112.21
5	Labour charges for fitting, fixing 200 mm x 200 mm x 160 mm., 140 mm x 140 mm x 160 mm., 110 mm x 110 mm x 160 mm. P.V.C.tee with 150 mm. dia. M.S. extension piece by using P.V.C. tail piece.	Each	112.21
6	Labour charges for fitting, fixing 160mm. dia. P.V.C.riser pipe with 150mm. dia. M.S. 90° bend by using P.V.C. tail piece.	Each	112.21
7	a) Testing of pipe line system against leakage by filling the distribution chamber with water and supplying water through the entire pipe line net work for at least 4 (four) hour including hiring and transport of suitable generator, pump, tools and plants, fuel and lubricants, installation of the pump, connecting the same with pipe line net work, making necessary electrical connection and dismantling all these after completion of test - all complete as per direction. i) For H.D.T.W. ii) For M.D.T.W.	Each System Each System	5610.55 3740.68

It. No.	Description of item	Unit	Basic Price in Rs
	b) Testing of pipe line system against leakages by filling the distribution chamber with water and supplying water through the entire pipe line net work for at least 4 (four) hour by running the departmental Diesel Engine pumping set, including supplying necessary fuels & lubricants and hiring and transporting tools and plants all complete as per direction of Engineer-in-Charge. i) For Major R.L.I. ii) For Midi R.L.I. iii) For Mini R.L.I.	Each System Each System Each System	4987.26 3324.84 2494.10
8	Labour charges for fitting, fixing 140 mm dia Flap valve with 140 mm dia class-II UPVC riser pipe with the help of FTP (flanged tail piece) by joining the PVC end of the tail piece and riser pipe with coupler and flanged end of tail piece and Flap valve with rubber insertion, nuts and bolts etc complete.(Rate inclusive of transportation from departmental store to work site).	Each	108.44
9	Labour charges for fitting, fixing (150 x 200) mm dia M S expander with 200 mm dia UPVC pipe with the help of FTP (flanged tail piece) by joining the PVC end of the tail piece and 200 mm dia UPVC pipe with coupler and flanged end of tail piece and expander with rubber insertion, nuts and bolts etc complete.(Rate inclusive of transportation from departmental store to work site).	Each	108.44
10	Labour charges for fitting, fixing 110 mm dia Flap valve with 110 mm dia class-II UPVC riser pipe / with 100 mm dia. AC pressure pipe with the help of FTP (flanged tail piece) by joining the PVC/ACP end of the tail piece and riser pipe with coupler and flanged end of tail piece and Flap valve with rubber insertion, nuts and bolts etc. complete. (Rate inclusive of transportation from departmental store to work site).	Each	108.44
11	Labour charges for fitting, fixing (150 x 140) mm dia M S reducer with 140 mm dia UPVC pipe with the help of FTP (flanged tail piece) by joining the PVC end of the tail piece and 140 mm dia UPVC pipe with coupler and flanged end of tail piece and expander with rubber insertion, nuts and bolts etc. complete. (Rate inclusive of transportation from departmental store to work site).	Each	108.44
12	Erection, fitting, fixing of set of M S Quadruped inlet and outlet pipe fittings for 1st chamber and 2nd chamber of Major RLI Scheme. (Rate inclusive of transportation from departmental store to work site).	Each set of 1st and 2nd chamber	29920.75
13	Erection, fitting, fixing of set of M S Quadruped inlet and outlet pipe fittings for HDTW / MIDI RLI Scheme.(Rate inclusive of transportation from departmental store to work site).	Each set	16622.32
14	Erection, fitting, fixing of set of M S Tripod inlet and outlet pipe fittings for MDTW / MINI RLI Scheme.(Rate inclusive of transportation from departmental store to work site).	Each set	12466.74
15	Installation of Diesel Engine Pumping set of any make / brand and for RLI scheme on pump foundation over SAL sleeper (to be supplied departmentally) by fixing nuts and bolts and making connection of suction hose and foot valve with necessary fittings at the inlet end of the water pump and fitting fixing of 90° M S priming bend, sluice valve and delivery hose with all necessary fittings at the delivery end of the water pump, duly connected with the pipe line, maintaining proper alignment and level including cutting holes on the wall of the pump house where necessary, mending good damages after completion of the works as per direction of Engineer-in-charge. (Pump set and all accessories will be supplied departmentally). a) For Major R.L.I. Scheme. b) For Midi R.L.I. Scheme. c) For Mini R.L.I. Scheme.	Each Set Each Set Each Set	1446.49 964.64 723.24

It. No.	Description of item	Unit	Basic Price in Rs
16	Supplying, fitting and fixing silencer arrangements made of 2 nos. 40 mm NB × 900 mm length short piece both ends standard threaded from 40 mm NB pipe conforming to IS : 1239/90 (part-1), 1 no. 40 mm NB GI reducing elbow both ends standard threaded, 1 no. 40 mm NB GI socket and 1 no NB × 150 mm long GI nipple, all of IS 1239/90 (Part-2) all complete as per direction of E.I.C.	Each	938.24
17	Supplying, fitting and fixing including transportation of sign board for identifying the exact location of MINI RLI scheme (one at road side and other at site) the board will be made 3 mm thick MS plate of size 300 mm × 600 mm and fitted and fixed on 50 mm GI Pipe of IS 1239/90 (part-1) including cutting, welding and writing of both sides of Sign board. Base - Yellow, and words - Red. Both bottom end of the stands pipe will be grouted in 1:2:4 CC on a single brick flat soling. This will include one materials and labour complete as per drawing and direction of E.I.C.	LS	3,677.51
18	Supplying 1 m × 0.6 m × 24 swg MS board containing list of spout wise water users by making numbers of spout as directed by EIC. The board should have base colour - Black and words - White to be fitted and fixed on the wall of the pump house.	LS	942.95
	<b>N.B. For Water transmission Arrangement of RLI / Tube well 4% extra over the schedule rates, save &amp; except for earth work in excavation &amp; filling works, will be allowed for extra carriage by cart / boat / head load besides initial transport by truck etc.</b>		

It. No.	Description of item	Unit	Basic Price in Rs
<b>2.30 LAYING INCLUDING REPAIRING OF R.C.C. PIPELINE IN H.D.T.W./R.L.I. SCHEME</b>			
1	Laying and joining of R.C.C. spun pipes with matching collars of different sizes mentioned below in field trenches including handling and carrying the pipes and matching R.C.C. collars from field stack, lowering the same within the trench, property positioning and levelling on bricks laid flat, filling the annular space between collar and the pipe joint with Jute braiding dipped in cement slurry, grouting with cement and sand mortar (1:2) mixed with approved quality water proofing compound (5% by weight of cement) including cost of cements, bricks for levelling, jute braiding etc.) and curing all complete as per direction of Engineer-in-Charge. (i) 2440mm. long 450mm. dia. (ii) 1830mm. long 300mm. dia. (iii) 1830mm. long 225mm. dia. (iv) 1830mm. long 150mm. dia.	Metre Metre Metre Metre	57.99 48.56 32.30 21.69
2	Jointing the undermentioned R.C.C. pipe fittings (pipeline specials) in the R.C.C. pipe line with matching R.C.C. collars including handling and carrying the fittings and matching R.C.C. collars from field stack, lowering in the trenches, properly levelling and positioning on bricks laid flat, filling the annular space between pipe fitting and collars with Jute braiding dipped in cement slurry, grouting with cement and sand mortar (1:2) mixed with approved water proofing compound (5% by weight of cement) and curing etc. complete as per direction of the Engineer-in-Charge (Cost of bricks for levelling and Jute braiding are included). (i) 450 mm × 450 mm × 225 mm. R.C.C. Tee (ii) 300 mm × 300 mm × 225 mm. R.C.C. Tee (iii) 225 mm × 225 mm × 225 mm. R.C.C. Tee (iv) 225 mm × 225 mm × 150 mm. R.C.C. Tee (v) 150 mm × 150 mm × 150 mm. R.C.C. Tee (vi) 450 mm × 300 mm. R.C.C. Reducer (vii) 300 mm × 225 mm R.C.C. Reducer (viii) 225 mm × 150mm. R.C.C. Cross (ix) 225 mm. R.C.C. Bend	Each Each Each Each Each Each Each Each Each	65.06 61.29 58.46 57.52 49.03 65.06 59.41 57.52 57.52
3	Jointing the end of 150 mm. dia. M.S. extension pipe for spout chamber with 150mm. end of R.C.C. Tee including carrying the M.S. extension pipe from store to site, levelling and positioning the end of extension pipe concentrically with 150mm. end of R.C.C. Tee on bricks laid flat within the field trench and jamming the joints with cement concrete (1:2:4) with stone chips 10 mm. down mixed with approved water proofing compound 5% by weight of cement) of adequate thickness to provide a leak proof joint as per direction of Engineer-in-Charge (Cost of bricks for levelling is included).	Each	81.09
4	Jointing plain end of 300 mm / 200 mm / 150 mm. Dia. M.S. special bend from surge tanks / shore manifold with underground R.C.C. pipe lines of 450mm. / 300mm. / 225 mm. dia. by jamming with cement concrete (1:2:4) with 10 mm. down stone chips mixed with approved water proofing compound (5% by weight of cement) of adequate thickness to provide a leak proof joint including carrying the special bend from departmental store to site, curing etc. as per direction of Engineer-in-Charge.	Each	83.92
5	Installation / Erection of SurgeTank / Shore manifold (to be supplied from Deptt. free of cost) over a rigid base of ordinary cement concrete (1:2:4) with graded stone chips (20mm. nominal size) of pakur variety of 1250 mm X 1250 mm X 150 mm. over a single layer of brick flat soling and embedding the legs of the surge tank/shore manifold within the concrete base including cost of all materials and labour and as per direction of Engineer-in-Charge.	Each	2263.08
6	Plugging the open end of 450mm. / 300 mm. / 225 mm. / 150 mm. dia. R.C.C. pipe line with cement concrete (1:2:4) with stone chips 20 mm. down mixed with water proofing compound(5% by weight of Cement) of approved quality including curing etc. complete as per direction of Engineer-in-Charge.		



It. No.	Description of item	Unit	Basic Price in Rs
	(i) 450mm. dia. R.C.C. pipe	Each	269.68
	(ii) 300mm. dia. R.C.C. pipe	Each	215.94
	(iii) 225mm. dia. R.C.C. pipe	Each	188.59
	(iv) 150mm. dia. R.C.C. pipe	Each	134.84
7	Fitting and fixing of M.S. / G.I. / C.I. accessories and special in pipe line (accessories & special to be supplied departmentally) including supply of jointing materials viz. rubber insertion, nuts & bolts, havoc Zink (Zink Oxide) complete as per direction of Engineer-in-Charge.		
	(i) 150mm. dia M.S. delivery hose with tail piece and clamps.	Each	33.00
	(ii) 150mm. dia. Suction hose with clamps and foot valve.	Each	33.00
	(iii) 350mm. dia. C.I. sluice valve	Each	67.89
	(iv) 150mm. dia. C.I. sluice valve	Each	54.69
	(v) 150mm. dia. C.I. NTP/ Alfa-Alfa valve.	Each	54.69
	(vi) 300 mm / 200 mm / 150mm. dia. M.S. special bend.	Each	49.03
	(vii) 150mm. dia. 90° M.S. bend with flanged ends	Each	49.03
	(viii) 150mm. dia. M.S. riser pipe with flanged ends	Each	49.03
	(ix) 80mm. dia 3 metres long G.I. pipe with one end flanged	Each	54.69
	(x) M.S. V-Notch plate	Each	134.84
8	Repairing of leakages in collar joints of R.C.C. Pipe line by opening the joints fully by chipping out the old mortar, cleaning the pipe recesses and collar properly, and thereafter positioning and levelling the pipes and collar, filling the annular spaces of joints with jute braiding dipped in cement slurry and grouting with (1:2) cement mortar mixed with approved quality water proofing compound (5% by wt. of cement) and curing all complete as per direction of Engineer-in-Charge.		
	(a) 450 mm dia. R.C.C. Pipe.	Each Joint	118.81
	(b) 300 mm dia. R.C.C. Pipe.	Each Joint	81.09
	(c) 225 mm dia. R.C.C. Pipe.	Each Joint	67.89
	(d) 150 mm dia. R.C.C. Pipe.	Each Joint	49.03
9	Taking out the damaged R.C.C. Pipe and two collars by dismantling two joints carefully, carrying and stacking the same near the pump house, carrying new pipe and collars from the field stack, lowering the same within the trench, properly positioning and levelling on bricks laid flat, between collar and the pipe joints with jute braiding dipped in cement slurry, grouting with cement and sand mortar (1:2) mixed with approved quality water proofing compound (5% by weight of cement) and curing all complete as per direction of Engineer-in-Charge.		
	(a) 450 mm dia. R.C.C. Pipe.	Each	221.59
	(b) 300 mm dia. R.C.C. Pipe.	Each	148.99
	(c) 225 mm dia. R.C.C. Pipe.	Each	115.98
	(d) 150 mm dia. R.C.C. Pipe.	Each	86.75
10	Taking out the damaged R.C.C. Tee and 3 nos. collars by dismantling three joints carefully, carrying and stacking the same near the pump house, carrying new R.C.C. Tee and collars from the field stack, lowering the same within the trench, properly levelling and positioning on bricks laid flat, filling the annular space between pipe fitting and collars with jute braiding dipped in cement slurry, grouting with cement and sand mortar (1:2) mixed with approved water proofing compound (5% by weight of cement) and curing etc. complete as per direction of Engineer-in-Charge.		
	(a) 450 mm × 450 mm × 225 mm R.C.C. Tee.	Each	188.59
	(b) 300 mm × 300 mm × 225 mm R.C.C. Tee.	Each	175.39
	(c) 225 mm × 225mm × 225 mm R.C.C. Tee.	Each	162.19
	(d) 225 mm × 225 mm × 150 mm R.C.C. Tee.	Each	148.99
	(e) 150 mm × 150 mm × 150 mm R.C.C. Tee.	Each	134.84

It. No.	Description of item	Unit	Basic Price in Rs
11	Taking out the condemned 150 mm dia. N.T.P./T.P./ Alfa-Alfa valve from 150 mm dia. M.S./G.I. pipe of existing spout chamber by careful chiseling with least disurbance to the existing system of structure upto required limit and fitting, fixing of new one with 150 mm dia. M.S./G.I. pipe in proper position of the spout chamber using havoc zinc jute so as to make the joint leak proof including mending good all damages and returning back the condemned materials at store as per direction of Engineer-in-Charge.	Each	81.09
	<b>N.B. For Water transmission Arrangement of RLI / Tube well 4% extra over the schedule rates, save &amp; except for earth work in excavation &amp; filling works, will be allowed for extra carriage by cart / boat / head load besides initial transport by truck etc.</b>		

It. No.	Description of item	Unit	Basic Price in Rs
<b>2.40 REPAIR OF P.V.C. PIPELINES OF HDTW / MDTW / RLI SCHEME</b>			
1	<p>Labour charge for replacement of different P.V.C. Accessories in different portion of P.V.C. Pipeline of HDTW / MDTW / RLI including taking out of the existing damage accessories, and excluding the supplying the new accessories of 4 Kg./cm<sup>2</sup> capacity and as per I.S. specification at site and fitting, fixing the same by joining with solvent cement (cost inclusive) after roughening up the surface with wire brush, emery papers etc., to make the joint leak proof all complete as per direction of Engineer-in-Charge.</p> <p>(i) 200 mm X160 mm. P.V.C. Reducer  (ii) 160 mm X140mm. P.V.C. Reducer  (iii) 200 mm X 200 mm X 160 mm. P.V.C. Tee  (iv) 140 mm X 140 mm X 160 mm. P.V.C. Tee  (v) 140 mm X 140 mm X 200 mm. P.V.C. Tee  (vi) 110 mm X 110 mm X 140 mm. P.V.C. Tee  (vii) 110 mm X 110 mm X 160 mm. dia. P.V.C. Tee  (viii) 200 mm X 200 mm X 200 mm. P.V.C. Tee  (ix) 140 mm. dia. 90°/60° &amp; 45° long bend  (x) 200 mm. dia 90°/ 60°/ 45° long bend  (xi) 160 mm. dia. 90° long bend  (xii) 150 mm. dia. . 90°/ 60° &amp; 45° long bend  (xiii) 160 mm. dia. flanged tail piece fitted with special bend  (xiv) 160 mm. dia. flanged tail piece fitted with Alfa-Alfa valve</p>	<p>Each  Each  Each  Each  Each  Each  Each  Each  Each  Each  Each  Each  Each  Each</p>	<p>80.15  80.15  119.75  119.75  119.75  119.75  119.75  119.75  99.95  99.95  99.95  99.95  130.13  130.13</p>
2	<p>Repair of puncture/holes of any size in existing P.V.C. Pipeline of HDTW/MDTW/RLI by placing half round P.V.C. Pipe section of required size to cover the holes/ puncture having adequate bearing on all sides and joining the half round section with solvent cement after roughening the surface with wire brush, emery paper to make the joint leak proof as per direction of Engineer-in-Charge (cost inclusive of supplying solvent cement at site and transportation of required length of P.V.C. Pipe to be issued departmentally, for cutting half round section, from Sub-Divisional Stores to site)</p> <p>(i) 315 mm dia. P.V.C. Pipe line  (ii) 200 mm dia. P.V.C. Pipe line  (iii) 140 mm dia. P.V.C. Pipe line  (iv) 110 mm dia. P.V.C. Pipe line</p>	<p>Each joint   — Do —  — Do —  — Do —  — Do —</p>	<p>   95.24  83.92  59.41  47.15</p>
3	<p>Labour charge for replacement of damage P.V.C. Pipe of any length in the Pipe line of HDTW / MDTW / RLI with new piece/s of pipe after taking out the damage pipe/s from the existing pipe line by cutting with hacksaw and joining the new pipe/s with the existing pipe line using necessary couplers after roughening up surface with wire brush, emery paper and applying the solvent cement (cost inclusive) to make the joint leakproof (pipe &amp; couplers to be supplied departmentally) including transporting departmentally issued pipe/s, couplers etc. from Sub-Divisional Store to the Site all complete as per direction of Engineer-in-Charge.</p> <p>(i) 315 mm. dia. P.V.C. pipe  (ii) 200 mm. dia. P.V.C. pipe  (iii) 160 mm. dia. P.V.C. pipe  (iv) 140 mm. dia. P.V.C. pipe  (v) 110 mm. dia. P.V.C. pipe</p>	<p>Each set of replacement   — Do —  — Do —  — Do —  — Do —  — Do —</p>	<p>   299.86  249.88  249.88  199.91  199.91</p>

**3.00 INSTALLATION OF 3/5/10/20 H.P.  
CENTRIFUGAL PUMPING SET.**

It. No.	Description of item	Unit	Basic Price in Rs
1	Placing and positioning the Centrifugal pump motor set on the pump base / pump house floor, aligning properly with necessary packing and fixing the set with holding down nuts and washer including cutting holes of requisite size in the floor / base, grouting the bolts and mending good all damages complete as per direction of the Engineer-in-Charge.		
	(i) 3 H.P./ 5 H.P. Capacity	Set	335.69
	(ii) 10 H.P. Capacity	Set	482.79
	(iii) 20 H.P. Capacity	Set	644.98
2	Labour charges for connecting the pump set with the shallow tubewell by fitting, fixing 80 mm dia. G.I. short piece with socket, 80 mm x 80 mm x 40 mm. dia. Bombay Tee with leather valve and tail piece and polythene house all complete as per direction.	Set	173.50
3	Labour charges for fitting, fixing hand tubewell on the Bombay Tee with 40 mm dia. G.I. Nipple as per direction.	Each	58.46
4	Labour charges for making delivery connection by fitting, fixing all complete as per direction.		
	(a) 50 mm. dia. G.I. Bend	Each	115.98
	(b) 50 mm. dia. 1500 mm. long G.I. short piece with 50 mm dia. G.I. Socket including cutting hole in the pump house wall.	Each	147.10
	(c) 65 mm x 80 mm. G.I. reducer.	Each	86.75
	(d) 65 mm dia., 150 mm. long G.I. short piece.	Each	86.75



It. No.	Description of item	Unit	Basic Price in Rs
3	Rewinding of different H.P 3 phase, 410-440 volts, 50 Hz, 2 / 4 poles submersible motor of different make with PVC insulated copper winding wire (1mm to 2mm nom. dia.) as per IS 8783, 1995, part 4 Sec 1 (FINOLEX/ INCABE make to be approved before use) as provided by the motor manufacturer including supplying fitting and fixing fire proof fibre chips on slots for keeping winding wires in position, taped by using water proof tape of 660 volts grade with main cable and fitted with water tight compound by using steel grip tape and vulcanised rubber tape by heating, changing thrust plate, ball retainer and ball including supplying fitting, fixing rings circlips for thrust plate, water seal ring, diaphragm, bush bearing etc. complete as per direction of E.I.C		
	(a) 3 H.P / 5H.P 3 Phase, 410-440 votls, 50 Hz, 2 pole, 4 amps - 7 amps submersible Motor (i) Supply of PVC insulated copper winding wire conforming IS 8783, 1995, part 4/ Sec 1 (1 mm nom. dia) Length of copper winding wire - max. 420 mts.	100 Mtr	989.15
	(ii) Labour charge for rewinding, water proofing, fitting and fixing fire proof fibre chips on slots for keeping winding wires in position, taped by using water proof tape of 660 volts grade with main cable and fitted with tight compound by using steel grip tape and vulcanised rubber tape by heating as per direction of E.I.C.	Each	1495.52
	(b) 12.5 H.P / 15 H.P 3 Phase, 410-440 votls, 50 Hz, 2 pole, 18 amps - 23 amps submersible Motor (i) Supply of PVC insulated copper winding wire conforming IS 8783, 1995, part 4/ Sec 1 (1.4 mm nom. dia). Length of copper winding wire - max. 450 mts.	100 Mtr	1938.71
	(ii) Labour charge for rewinding, water proofing ,fitting and fixing fire proof fibre chips on slots for keeping winding wires in position, taped by using water proof tape of 660 volts grade with main cable and fitted with tight compound by using steel grip tape and vulcanised rubber tape by heating as per direction of E.I.C.	Each	1645.45
	(c) 17.5 H.P / 19.25 H.P / 20 HP 3 Phase, 410-440 votls, 50 Hz, 2 pole, 26 amps - 30 amps submersible Motor (i) Supply of PVC insulated copper winding wire conforming IS 8783, 1995, part 4/ Sec 1. Length of copper winding wire - max. 450 mts.		
	i-a) 1.5 mm nom. Dia for 17.5 H.P	100 Mtr	2196.13
	i-b) 1.6 mm nom. Dia for 19.25 H.P	100 Mtr	2472.41
	i-c) 1.7 mm nom. Dia for 20 H.P	100 Mtr	2765.67
	(ii) Labour charge for rewinding, water proofing, fitting and fixing fire proof fibre chips on slots for keeping winding wires in position, taped by using water proof tape of 660 volts grade with main cable and fitted with tight compound by using steel grip tape and vulcanised rubber tape by heating as per direction of E.I.C.	Each	1719.00
	(d) 21 H.P / 22.5 H.P 3 Phase, 410-440 votls, 50 Hz, 2 pole, 30 amps - 33 amps submersible Motor (i) Supply of PVC insulated copper winding wire conforming IS 8783, 1995, part 4/ Sec 1 (1.7 mm nom. dia). Length of copper winding wire - max. 450 mts.	100 Mtr	2765.67
	(ii) Labour charge for rewinding, water proofing, fitting and fixing fire proof fibre chips on slots for keeping winding wires in position, taped by using water proof tape of 660 volts grade with main cable and fitted with tight compound by using steel grip tape and vulcanised rubber tape by heating as per direction of E.I.C.	Each	1794.43
	(e) 25 H.P 3 Phase, 410-440 votls, 50 Hz, 2 pole, 37 amps submersible Motor (i) Supply of PVC insulated copper winding wire conforming IS 8783, 1995, part 4/ Sec 1 (1.8 mm nom. dia). Length of copper winding wire - max. 450 mts.	100 Mtr	3071.19

It. No.	Description of item	Unit	Basic Price in Rs
	(ii) Labour charge for rewinding, water proofing, fitting and fixing fire proof fibre chips on slots for keeping winding wires in position, taped by using water proof tape of 660 volts grade with main cable and fitted with tight compound by using steel grip tape and vulcanised rubber tape by heating as per direction of E.I.C.	Each	1868.93
	(f) 30 H.P 3 Phase, 410-440 volts, 50 Hz, 2 pole, 38 amps - 44 amps Submersible Motor		
	(i) Supply of PVC insulated copper winding wire conforming IS 8783, 1995, part 4/ Sec 1 (2 mm nom. dia). Length of copper winding wire - max. 500 mts.	100 Mtr	3554.92
	(ii) Labour charge for rewinding, water proofing, fitting and fixing fire proof fibre chips on slots for keeping winding wires in position, taped by using water proof tape of 660 volts grade with main cable and fitted with tight compound by using steel grip tape and vulcanised rubber tape by heating as per direction of E.I.C.	Each	1944.36
4	Testing of repaired motor by contious 8 hrs running on load as per direction of E.I.C.	Each	429.04
5	Carriage of motor from store to workshop and back to store after repair. This item is only applicable when written permission is available from E.I.C. where there is no facility for such work in the sub- division.	Each	212.16
6	Deduction towards dismantled burnt enamelled copper wire from induction motor on the basis of actual measurement to be retained by the agency. (Note: In case of PVC insulated copper wire to arrive at net burnt weight 10% deduction will be made)	Kg	195.19
7	Socketing with C.I socket at enlarged bearing housing of any type of 17.5 H.P / 20 H.P motor by oversizing the bearing housing by machine turning & suppling new socket of required size and fitting the same in bearing housing.	Each	433.76
8	Heat varnishing with best quality (Johnson & Johnson / Dr. Beck/ Giliander) class 'E' insulating varnish of required quantity for 3 course & uniform heating at 80° C for 48 hrs. with all cost of materials, labour ar per direction of E.I.C.		
	(a) Insulating varnish 1/4 lit for 3 HP induction motor	Each	257.43
	(b) Insulating varnish 1/2 lit for 10 HP induction motor	Each	548.80
	(c) Insulating varnish 1 lit for 20 HP induction motor	Each	711.93
9	Painting two coats of both inner & outer portion with best quality synthetic enamel paint (to be approved before use) including smoothing surface by sand paper for removing old paint as per direction of E.I.C.		
	(a) Motor	Each	171.62
	(b) Pump	Each	128.24
<b>For 3 H. P. / 5 H. P.</b>			
10	(a) Supplying, fitting and fixing diaphragm.	Each	24.52
	(b) Supplying , fitting and fixing 'O' Rings (consisting of 4/8 nos.)	Each	18.86
	(c) Supplying, fitting and fixing winding protector of both sides. (Top and Bottom)	Each	24.52
	(d) Supplying, fitting and fixing bearing bush as per approval of the Engineer-in-charge. (four nos.)	Each	157.47
	(e) Supplying, fitting and fixing drain plug with packing & washer.	Each	34.89
	(f) Supplying, fitting and fixing of stud with clamp for top and bottom cover complete (consisting of 8 nos.)	Each	26.40
	(g) Sypplying, fitting and fixing stud for upper/lower flange.	Each	8.49
	(h) Sypplying, fitting and fixing of water steel bolt.	Each	39.60
	(i) Charge for joining water proof cable with soldering water proof insulation and proper joining compound including supplying the same and motor related materials complete (only cable will be supplied departmentally)	Each	42.43
	(j) Repairing charge of damaged rotor including metal grinding machining etc. of the rotor shaft to match with original including supply in the regd. Materials complete. (Payment against this item will be made when this item will be made on the specific direction of the Engineer-in-charge).	Each	117.87
	(k) Supplying fitting and fixing clutch on the thrust plate as per direction of Engineer-in-charge	Each	110.33

It. No.	Description of item	Unit	Basic Price in Rs
	(l) Supplying, fitting and fixing thrust bearing segment with steel bolts on the thrust bearing housing (set of six nos.)	Each	47.15
	<b>For 12.5 H.P. and above</b>		
11	(a) Repairing of damaged motor shaft by metaling with electric welding and turning properly to house in the bearing space and coupling side teeth and also rectifying the dynamic balance of the rotor to its original alignment to avoid any vibration all complete as per direction of the E.I.C.	Each	227.25
	(b) Supplying, fitting and fixing the winding protector on both sides (Top and Bottom)	Each	68.84
	(c) Supplying, fitting and fixing the bush bearing for motor in place of damaged as per approval and direction of the Engineer-in-charge. i) Top for Motor. ii) Bottom for Motor	Each Each	355.49 434.70
	(d) Supplying, fitting and fixing drain plug made from brass metal with gasket and washer (one for drain plug one for water filling plug and one for verting plug)	Each	145.21
	(e) Supplying, fitting and fixing stud bolt with nuts for top and bottom cover	Each	120.70
	(f) Supplying, fitting and fixing stud bolt with nuts and washer for upper flange as per sample	Each	19.80
	(g) Supplying, fitting and fixing thrust bearing retainer as per sample	Each	92.41
	(h) Joining water proof cable with the leads of the motor including soldering with requisite water proof insulation and proper joining compound/Vulcanized rubber tape so that proper water proof insulation is assured.	Each set	99.01
	(i) Supplying, fitting and fixing s.s. slip of rotor shaft including removing out of the old one as per direction of the E.I.C.	Each set	378.12
	(j) Supplying, fitting and fixing feroasbestos lining on the thrust plate as per direction of the E.I.C.	Each	257.43
	(k) Supplying fitting and fixing axial thrust plate of motor shaft including supplying of key etc. all complete as per direction of Engineer-in-charge. i) 12.5 H. P. to 20 H. P. ii) 22.5 H. P. and above.	Each Each	549.74 1256.95
	(l) Supplying, fitting and fixing pivot segment steel balls on the thrust bearing housing as per direction of the E.I.C. ( 6 nos. in one set with rubber guarder/Circlip etc.) i) 12.5 H.P. to 15 H.P. ii) 17.5 H.P. to 20 H.P. iii) above 20 H.P.	Each set Each set Each set	57.52 63.18 71.66
	(m) Supplying, fitting and fixing of (thrust bearing segment) Pivot segments (Set of 6) made from phosphorus bronze as per sample and as per direction of E.I.C. i) 12.5 H.P. to 15 H.P. ii) 17.5 H.P. and above	Each set Each set	1542.67 1800.09
	(n) Supplying, fitting and fixing the self aligning thrust plate of the motor shaft including supplying of key etc. all complete as per direction of E.I.C.	Each	177.27
	(o) Re-assembling the submersible motor after completion of rewinding and repainting and allied work with the repaired spares parts or new spares where necessary (to be supplied departmentally on requisition) including checking of all accessories and supplying necessary screws nuts and fitting fixing the whole thing properly as per direction the E.I.C.	Each	143.33
12	Labour charge for checking up the dynamic balance of the motor shaft for original alignment as per direcion of Engineer-in-Charge.	Each	197.08



**5.00 INSTALLATION AND WITHDRAWAL OF V.T. & SUBMERSIBLE PUMP**

It. No.	Description of item	Unit	Basic Price in Rs
1	<p>Installation of submersible electro motor pumping set of following capacities by using necessary requisite, tools and plants by lowering the same within the tubewell housing pipe upto the following depth as per direction by fitting, fixing column pipes and other accessories, fixtures with necessary nuts, bolts and washers and suspending the entire assembly of pump set vertically by fixing the same supported by M.S. clamps over the top of housing pipe, binding the motor cable with each column pipes and drawing cable upto pump controller/starter point including opening out of the top cap of housing pipe of the tubewell and testing of motor both in loading as well as in unloaded condition before and after installation of the same. (The rate is inclusive of hiring charges of tools &amp; plants.)</p> <p>(a) 100/150/200 cubic metre per hour capacity electro motor pumping set.</p> <p>(i) Length of pump assembly not exceeding 18 metre length.</p> <p>(ii) Length of pump assembly of any length exceeding 18 metre length.</p>	Per set Per set	1277.70 1510.61
2	<p>Withdrawal of electro motor submersible pumping set of following capacities from within the tubewell housing pipe of the following length by using all necessary requisites tools and plants and carefully as per direction of Engineer-in-Charge and stacking the same properly at site within the tubewell premises complete.</p> <p>(a) 100/150/200 cubic metre per hour capacity electro motor pumping set.</p> <p>(i) Length of pump assembly not exceeding 18 metre length.</p> <p>(ii) Length of pump assembly of any length exceeding 18 metre length.</p> <p>(b) 30 cubic metre per hour capacity electro motor pumping set.</p> <p>(i) Length of pump assembly not exceeding 18 metre length.</p> <p>(ii) Length of pump assembly of any length exceeding 18 metre length.</p>	Per set Per set  Per set Per set	581.80 696.84  812.82 1045.73  464.87 581.80
3	<p>Installation of vertical turbine pump set by using necessary requisite tools and plants by lowering the same within the tubewell housing pipe upto the following length as per direction by fitting and fixing of Bowl Assembly, shaft with shaft coupling, oil tube, bearing and column pipes with necessary fixtures namely stabilizer, Centre guide, discharge head, T.T. Plate, Nut, etc. all complete as per direction and stacking properly within tubewell premises. (The rate is inclusive of hiring charges of tools and plants.)</p> <p>(a) 200 cubic metre per hour capacity pump assembly upto any depth.</p>	Each set	2905.23
4	<p>Withdrawal of vertical turbine pumping set from within the tubewell housing pipe upto the following depth by using necessary tools and plants and stacking each component namely Bowl assembly, housing pipe, oil tube, shaft, bearing, coupling, T.T. Nut bolt, discharge head, top shaft etc. within the tubewell premises as per direction all complete. (The rate is inclusive of hiring charges of tools and plants).</p>	Each set	1626.59
5	<p>(a) Dismantling Submersible pump / Bowl assembly suitable for a capacity of 30 / 150 / 200 Cum per hour capacity against a total head of 15 mtrs to 30 mtrs of different make and segregating all spares fitted with the pump including washing and cleaning the same thoroughly for verification of servicable and unservicable spares as per direction of the Engineer-in-Charge.</p> <p>(b) Dismantling vertical turbine pump suitable for a capacity of 30 / 150 / 200 Cum per hour capacity against a total head of 15 mtrs to 30 mtrs of different make and segregating all spares fitted with the pump including washing and cleaning the same thoroughly for verification of servicable and unservicable spares as per direction of the Engineer-in-Charge.</p>	Each Item  Each Item	103.72  103.72

KM  
/

It. No.	Description of item	Unit	Basic Price in Rs
6	(a) Labour charges for re-assembling the submersible pump after completion of repairing spare etc. and allied works with repaired spares or new spares when necessary to be supplied departmentally which are not provided in schedule including screws, nuts, lubricating materials etc. as required as per direction of Engineer-in-Charge.	Each	439.41
	(b) Labour charges for re-assembling the vertical turbine pump after completion of repairing spare etc. and allied works with repaired spares or new spares when necessary to be supplied departmentally which are not provided in schedule including screws, nuts, lubricating materials etc. as required as per direction of Engineer-in-Charge.	Each	439.41
7	(a) Painting 2 (two) coats of both inner and outer portion of submersible pump with best quality synthetic enamel paint of approved make and brand including smoothening surface by sand papering after removal of old paint as per direction of Engineer-in-Charge.	Each	182.93
	(b) Painting 2 (two) coats of both inner and outer portion of vertical turbine pump with best quality synthetic enamel paint of approved make and brand including smoothening surface by sand papering after removal of old paint as per direction of Engineer-in-Charge.	Each	182.93
8	<b>For pump for 3 H.P. / 5 H.P. motor</b>		
	(a) Supplying, fitting and fixing of bearing bush made of stainless steel as per required shape & size duly approved by the Engineer-in-Charge.	Each	165.02
	(b) Supplying, fitting and fixing of pump coupling as per requirement.	Each	362.09
	(c) Supplying, fitting and fixing dynamic filter with circlip and rubber washer for lubricating pump bush as per direction of the Engineer-in-Charge.	Each	106.55
	(d) Supplying, fitting and fixing the bowl bush made of phosphorus, bronze or in original suitable for particulars size pump with water fitting screws as per direction of the Engineer-in-Charge (four nos.).	Each	215.94
	(e) Supplying, fitting and fixing the impeller seal ring made of phosphorus, bronze as per direction of the Engineer-in-Charge (four nos.).	Each	250.82
9	<b>For pump for 12 H.P. Motor and above size</b>		
	(a) Repairing of stage bowl and other spares when necessary by welding, turning and rethreading including supplying and fitting, fixing new studs nuts, washers, impeller key, coupling key with lock nut complete as per direction of Engineer-in-Charge.	Each	343.23
	(b) Repairing impeller by metallic gas/electric welding with gunmetal stick & turning, fitting, fixing in proper position as per direction of Engineer-in-Charge.	Each	449.79
	(c) Supplying, fitting and fixing stainless steel shaft as per sample and approval of the Engineer-in-Charge.	Each	884.49
	(d) Supplying, fitting and fixing G.M. sleeve to be fitted in the bowl bush/body bush suitable for specified R.P.M.	Each	330.03
	(e) Supplying, fitting and fixing the body (Bowl) Bush (Suitable for specified R.P.M. of pump (Motor set) as per direction of the Engineer-in-Charge. (two nos.)	Each	441.30
	(f) Supplying, fitting and fixing stainless steel pump coupling as per sample.	Each	491.28
	(g) Supplying, fitting and fixing steel sleeves with 2 Nos. S. S. Nut as per site and sample (two nos.).	Each	235.74
	(h) Supplying, fitting and fixing ceramic filter with circlip and rubber guarder (original of a particular make of pump).	Each	216.88
	(i) Supplying, fitting and fixing Impeller seal ring made of phosphorus.	Each	323.43
	(j) Supplying, fitting and fixing sand guard made of Gun Metal as per direction of the Engineer-in-Charge.	Each	392.27
	(k) Charges for repairing continuity test, insulation test by Megger, no load test as per direction of Engineer-in-Charge.	Each	321.55

## 6.00 SURGING AND MAINTENANCE OF TUBEWELL

It. No.	Description of item	Unit	Basic Price in Rs
1	Cleaning of annular space (1.2 metre dia) around housing pipe by excavation for exposing the top of gravel layer, including making shoring and shuttering arrangement as necessary and removing the spoils to a safe distance all complete as per direction of the Engineer-in-Charge. (Measurement to be taken as depth excavated from floor level of pump house).	Metre	466.76
2	Charges for placing 1.2 metre dia. 300 mm. wide, 65 mm thick R.C.C. well ring made with cement concrete 1:1.5:3 with stone chips and 0.8% reinforcement (including the cost of shuttering and reinforcement) cast at site in the annular space around the housing pipe, including supplying the rings at site-all complete as per direction of the Engineer-in-Charge.	Metre	2,093.35
3	Supply of acid component including all taxes and charge and carrying cost at site. a) Sulphamic Acid b) Calcium Hypochlorite c) Sodium Hexameta Phosphate	Kg. Kg. Kg.	89.58 70.72 80.15
4	Labour Charges for pouring the acid in requisite quantities in perforated polythine one cloth bag & submersing the bags within the tube well at different stages of strainer with the help of string overnight, weeping and their mixing and string the acid with surge block by air Compressor (including back pressure) L. S.	Each	1,471.94
5	Development of tubewell with not less than 350 cfm 150 psi capacity air compressor by surging and back washing for minimum 12 hrs including lowering of eduction pipe, air pipe etc. upto required depth as per direction of Engineer-in-Charge including hire and transport charge of Air compressor and other necessary tool and plants and also cost of fuel / lubricants for air compressor.	Hrs.	1,091.94
6	Supply of gravel for use as pack in tube well of 2 mm to 4 mm. size and gravel treatment of tubewell (as per IS: 4097/ 1967) including screening, washing, cleaning etc. of the gravels at the site, all complete as per direction of the Engineer-in-Charge	Cu.M.	2,227.25
7	Labour charges & other charges for lowering of drop pipe 7.5 cm. or 10 cm. dia for choke clearance & detection of parted point (for parted tubewell) on fitting necessary flanges buckets & other attachment as may be required & withdrawing of the same after completion of work as many lifting & lowering required during the work without damaging any departmental material including lowering of sounding wire time to time as and when required. This includes labour & other charges for erection of scaffolding for lowering & withdrawing drop pipe. (i) Upto 60 metre depth. (ii) Beyond 60 metres upto 150 metres. (iii) Beyond 150 metres upto 200 metres.	Metre Metre Metre	41.49 45.26 49.98
8	Labour charges & other charges for clearing of parted particle like sand and gravel & foreign materials like brick bats etc. if any from inside the tubewell assembly from different depth adopting suitable method including use of suitable type of cutter for loosening & breaking the deposited materials on subsequent operation of air compressor of suitable capacity with gradual & time to time lowering of compressor pipes, drop pipes etc. for required hours till the chockage is cleared upto the satisfaction of Engineer-in-Charge. (The rate included all labour charges & running cost of machinery but excluding lowering of drop pipe & other tools and plants but included labour charges for lower cutter, air pipe etc. to the required depth as needed. (i) Upto 60 metre depth. (ii) Beyond 60 metres upto 150 metres. (iii) Beyond 150 metres upto 200 metres.	Metre Metre Metre	238.57 285.71 359.26
9	Labour charges & other charges for pouring water (if required in side the tubewell) for operation of air compressor during chemical treatment from outside the surface by any means including drawing pipe line or excavation earth channel hire charges of tools & plants etc. complete.	Each tubewell	1,006.13

(7)

It. No.	Description of item	Unit	Basic Price in Rs
10	Making of capsule for sealing parted portion at reducer on cutting required length upto 10 ft. from 6 inches dia. Pipe (to be supplied departmentally) including supplying fixing of 2 nos., 2 inch, ½" to 1" width rubber ring 7.5 inches o.d. in between two M.S. on one end of the pipe & fixing of one flange at middle position of pipe having outer dia. more than 8 inches but less than 11 inch. and also fixing of 2 nos. M.S. flanges type plate having other ¼ inch. less than inner dia. of housing pipe and setting of one to two nos. rubber packing ½ inch. to 1 inch. thick and suitable outer dia. (just below the inner dia.) of housing on the other end of pipe as per direction. The capsul should be prepared in such way so that it can guard the parted portion effectively and at the same time it can move through the assembly easily complying optimum pressure and also it rest on the reducer freely. (The rate including cut ting charges necessary welding, threading, matching and including supplying of two nos. M.S. ring, one no. M.S. flange, two nos. M.S. flange type plate, necessary rubber packing ring of suitable dia.and thickness, necessary rubberpacking ring of suitable dia and thickness necessary provision for lowering capsul and includes all necessary carriage departmental stores to workshop and to work site all complete.	Each Tubewell	1,946.25
11	Labour charges & other charges for lowering of sealing a capsul within the housing / reducer with the help of 8 mm dia wire rope or by any other arrangements on employing optimum thrust with the help of 3 inch. dia of pipe & placing the capsul in proper position to guard the parted portion effectively including all the hire charges of tools & plants & labour charges & other incidental charges etc. all complete (payment will be made only after effective sealing of parted zone).	Each Tubewell	558.23
12	(i) Supplying of flexible wire rope of good quality 6 mm dia. at site.	Mtr.	16.97
	(ii) Supplying suitable size dog clamp.	Each	12.26
13	Manufacturing of 160/140/110 mm dia. P.V.C. strainer by making slot of suitable size as per design on the body of the P.V.C. pipe covering same with good quality nylon net and closely winding the same with good quality of coir rope (P.V.C. pipe to be supplied by their department) including all labour & transportation charges complete.	Mtr.	219.71
14	Manufacturing of 160/140/110 mm dia. P.V.C. strainer by making slot of suitable size as per design on the body of the P.V.C. pipe covering same with good quality nylon net and closely winding the same with good quality of coir rope (P.V.C. pipe to be supplied by their department) including all labour & transportation charges complete.	Mtr.	11.32

## 7.00 REPAIR OF STEEL BARGE AND OTHER SIMILAR NATURE OF WORKS

It. No.	Description of item	Unit	Basic Price in Rs
1	Shifting of barge to a suitable working site or place from the R.L.I. site and blocking of the barge by area clearance, earth cutting, winching, jacking, planking, block fixing and un-jacking and placing of the R.L.I. site including tools and plants for blocking.		
	(a) Twin Hull Barge (16'-6" × 9'-0" × 3'-0")	Each	4,144.27
	(b) Small Hatch Barge (22'-0" × 10'-0" × 4'-6")	Each	4,440.35
	(c) Pump Barge/Big Hatch Barge (35'-0" × 13'-0" × 5'-6")	Each	5,599.24
2	Removing the pump set installed on the barge from the foundation including disconnection, removal of suction and delivery assemblies from the barge to a secured place and re-fitting of the same properly after the maintenance of the barge.	Per set	1,205.09
3	Opening, straightening and refitting of plates, angles, purlines, trusses, bollard, expanded metal/ B.R.C. net, winch etc. as required and as per direction of Engineer-in-Charge.		
	(a) Twin Hull Barge (16'-6" × 9'-0" × 3'-0")	Each	903.35
	(b) Small Hatch Barge (22'-0" × 10'-0" × 4'-6")	Each	903.35
	(c) Pump Barge/Big Hatch Barge (35'-0" × 13'-0" × 5'-6")	Each	1,356.91
4	Patch/Doubling works complete with M.S. plate including welding, gas cutting, fitting, fixing complete.		
	(a) Cost of 5 mm M.S. plate including wastage due to cutting, including labour charges for straightening fitting, fixing in position.	Sqm	2,432.81
	(b) Gas cutting to required size upto 8 mm thick M.S. plate, M.S. channel, angle etc. including labour charges, hire charges for all tools and plants.	Metre	185.76
	(c) Electric welding charges upto 8 mm M.S. plate, M.S. channel etc. and other member of the barge including hiring charges of all tools and plants.	Metre	434.70
5	Supply, fitting, fixing complete :		
	(a) Galvanised corrugated iron sheet work (excluding the supporting frame work) fitted and fixed with 10 mm. dia J or L hook-bolts, limpet and bitumen washers and putty complete with 150 mm. end lap and one corrugation minimum side lap, with 0.60 mm thick in roof. (Payment to be made on area of finished work) (GCI sheet to be supplied by contractor)	Sqm	683.64
	(b) Galvanised iron sheet ridging fitted with necessary bolts, screws, washers etc complete. (225 mm end lapping) with 0.60 mm sheets, 300 mm lapping each way.	Metre	390.38
6	Supplying, fitting and fixing of I.R.C. net (75 mm × 25 mm × 10 swg) with nuts and bolts of the barge including gas cutting etc.	Sqm	276.28
7	Supplying 1.5 mm (16 SWG) M.S. sheet fitted and fixed on one or both faces of M.S. bar etc. with point welding not more than 150 mm apart complete in all respect and including cost of labour and materials as per direction of Engineer-in-Charge.	Sqm	1,039.13
8	(a) Supplying, fitting & fixing of M.S. angle (Size : 45 mm × 45 mm × 6 mm) including gas cutting etc.	Metre	219.71
	(b) Supplying, fitting & fixing of M.S. angle (Size : 50 mm × 50 mm × 6 mm) including gas cutting etc.	Metre	238.57

KM  
—



It. No.	Description of item	Unit	Basic Price in Rs
16	<p>M.S. structural works with hollow sections (square or rectangular shape) conforming to IS: 806-1957 &amp; IS:1161-1958) connected to one another with bracket, gusset, cleat as per design, drawing &amp; direction of Engineer-in-Charge complete including cutting to requisite shape &amp; size, fabrication including metal arc welding conforming to IS: 816-1956 &amp; IS: 9595 using electrodes of approved make and brand conforming to IS:814-1957, haulage, hoisting and erection all complete.</p> <p>The rate includes the cost of all M.S. Hollow section, all consumables such as electrodes, gas and hire charges of all tools and plants and labour required for execution and all incidental chages (such as electricity, labour insurance) etc. complete.</p> <p>Payment to be made on the basis of calculated weight of structural memebhrs of MS Holow Section as specified in relevent IS code in finished work. Payment for gusset, bracket, cleat may be made by adding the actual weight of such items with weight of finished structural members. The rates are considered for a hight of erection 8 m. / 2nd floor level from the ground. Add 1.5 % extra over the rate for each additional floor or 4m. beyond the initial 8 m. or part thereof.</p>		
	For other Structural works	MT	66,537.38

KM

## 8.00 CARRIAGE OF MATERIALS

It. No.	Description of item	Unit	Basic Price in Rs
1	Labour charges for unloading the following materials from Rly. wagons by head load and stacking the same as per direction within the Rly. yards. a) Steel, rods, coils etc. b) Cement	Ton Ton	98.07 88.64
2	Charges for unloading of ERW/MS pipe of following diameter and 10 to 12 metre average length from any type of Rly. wagons, manually or by engaging cranes of appropriate capacity, and stacking the same within the Rly. yards and cutting into pieces by using oxy-acetylene flame as per direction of Engineer-in-Charge. a) 350 mm. dia. b) 300 mm. dia. c) 250 mm. dia. d) 200 mm. dia. e) 150 mm. dia. (The Contractor is required to take delivery of the materials immediately on arrival of the wagons, and to unload and stack the same at Rly.yard or station for immediate removal to destination and clearing the Rly. yard or station within the permissible time limit. Any demurrage, wherefage etc. that may have to be paid or any transit arrangement that the contractor may take to avoid such charges shall be entirely at his own cost).	Metre Metre Metre Metre Metre	25.46 23.10 16.97 11.32 8.49
3	Labour for loading the following materials into trucks, carts, boats etc. at lifting point and unloading the materials at the destination and stacking the same as per direction including carriage by headload upto a lead of 100 metres at each end. a) Steel rods, coils, etc. b) Cement c) ERW / MS Pipe i) 350 mm. dia. ii) 300 mm. dia. iii) 250 mm. dia. iv) 200 mm. dia. v) 150 mm. dia. vi) 75 mm / 80 mm. dia.	Ton Ton metre metre metre metre metre metre	155.59 93.35 34.42 32.06 25.93 17.44 11.79 6.60
4	Labour charges for each addl. carriage of 50 m by head load (or part thereof) beyond the initial 100 m at loading or unloading points. a) Steel rods, coils etc. b) Cement	Ton Ton	23.57 14.14
5	(i) Labour for loading R. C. Spun pipes (NP-2) into trucks, carts etc. at lifting point & unloading the materials at destination point & stacking the same in stackyard or go-down as per direction including carriage within a lead of 100 m (or part thereof) at each end. a) Pipes and collars of dia. 225-300 mm. b) Pipes and collars of dia. 450 mm. c) Pipes and collars of dia. 600 mm. d) Pipes and collars of dia. 750 mm. e) Pipes and collars of dia. 900 mm. (Add 20% extra for NP-3) (ii) Labour for loading A.C pipes into trucks, carts etc. at lifting point & unloading the materials at destination point & stacking the same in stackyard or go-down as per direction including carriage within a lead of 100 m (or part thereof) at each end. a) 200 mm dia b) 150 mm dia c) 125 mm dia d) 100 mm dia	metre metre metre metre metre metre metre metre metre metre metre metre	22.63 27.82 35.83 38.66 44.32 5.19 4.71 4.48 4.24

KM



It. No.	Description of item	Unit	Basic Price in Rs
6	Extra rate for each additional carriage of 50 m (or part thereof) beyond initial lead of 100 m. at loading & unloading point. (a) Pipe & Collars of (NP 2) dia. 225-300 mm. (b) Pipe & Collars of (NP 2) dia. 450-525 mm. (c) Pipe & Collars of (NP 2) dia. 600-675 mm. (d) Pipe & Collars of (NP 2) dia. 750-825 mm. (e) Pipe & Collars of (NP 2) dia. 900 mm. (Add 20% extra for NP-3)	metre metre metre metre metre	3.77 4.24 5.66 6.13 7.07
7A	Carriage of miscellaneous materials over pucca road upto 5 km. distance (a) Cement (b) Steel (c) ERW /MS pipe (i) 350 mm. dia. (ii) 300 mm. dia. (iii) 250 mm. dia. (iv) 200 mm. dia. (v) 150 mm. dia. (vi) 75 / 80 mm. dia.	Ton Ton metre metre metre metre metre	121.64 140.50 16.03 11.79 9.90 8.02 6.13 5.19
7B	(a) Cement/Steel (i) For carriage beyond 5 km and upto 25 km (ii) For carriage beyond 25 km and upto 50 km (iii) For carriage beyond 50 km and upto any distance (b) ERW/MS pipe (i) For carriage of 350 mm dia Beyond 5 km and upto 50 km From 50 km upto any distance (ii) For carriage of 300 mm dia Beyond 5 km and upto 50 km From 50 km upto any distance (iii) For carriage of 250 mm dia Beyond 5 km and upto 50 km From 50 km upto any distance (iv) For carriage of 200 mm dia Beyond 5 km and upto 50 km From 50 km upto any distance (v) For carriage of 150 mm dia Beyond 5 km and Upto 50 km From 50 km upto any distance (vi) For carriage of 80 mm dia Beyond 5 km and upto 50 km From 50 km upto any distance	Ton/Km Ton/Km Ton/Km 100m/ Km 100m/ Km 100m/ Km 100m/ Km 100m/ Km 100m/ Km 100m/ Km 100m/ Km 100m/ Km 100m/ Km 100m/ Km 100m/ Km	11.79 8.02 5.19 39.13 23.57 31.12 19.57 27.35 15.56 23.57 11.79 19.57 11.79 15.56 9.19
8	(i) Carriage of R.C. pipes & collars over pucca road upto 5 Km. distance (for NP-2). (a) Pipe, Collars of 225 mm. dia. (b) Pipe, Collars of 300 mm. dia. (c) Pipe, Collars of 450 mm. dia. (d) Pipe, Collars of 600 mm. dia. (e) Pipe, Collars of 750 mm. dia. (f) Pipe, Collars of 900 mm. dia. (Add 20% extra for NP - 3) (i) Carriage of A.C. pipes & collars over pucca road upto 5 Km. distance. (a) Pipe, Collars of 200 mm. dia. (b) Pipe, Collars of 150 mm. dia. (c) Pipe, Collars of 125 mm. dia. (d) Pipe, Collars of 100 mm. dia.	metre metre metre metre metre metre metre metre metre metre metre metre	7.07 15.56 24.99 35.36 46.20 69.31 3.06 1.89 1.41 0.94
9	(i) Extra rate for carriage of R.C. pipes & collars over pucca road beyond 5 Km. upto any distance (for NP-2). (a) Pipes & collars of 225 mm. dia. (b) Pipes & collars of 300 mm. dia. (c) Pipes & collars of 450 mm. dia. (d) Pipes & collars of 600 mm. dia. (e) Pipes & collars of 750 mm. dia. (f) Pipes & collars of 900 mm. dia. (Add 20% extra for NP - 3)	100m/ Km 100m/ Km 100m/ Km 100m/ Km 100m/ Km 100m/ Km	70.72 141.44 235.74 282.89 353.61 400.75



It. No.	Description of item	Unit	Basic Price in Rs
	(ii) Extra rate for carriage of A.C. pipes & collars over pucca road beyond 5 Km. upto any distance a) 200 mm dia b) 150 mm dia c) 125 mm dia d) 100 mm dia Note : For the purpose of items of carriage of materials over pucca road and kutcha road (including earthen roads or morrum roads), if involved in part or full within the approved route chart, shall be converted to equivalent pucca road by multiplying the distance of kutcha road by a factor of 1.5. The distance including equivalent distance shall be rounded off to 0.5 km.	100m/ Km 100m/ Km 100m/ Km 100m/ Km	28.29 9.43 9.43 9.43
10	Unloading from truck P.V.C. pipes of 300-200-160-140-110 mm dia 2 to 4 kg/cm <sup>2</sup> capacity and average length of 6 metre kept in telescopic arrangement and stacking in godown/site as per direction including carriage by headload within lead of 50 metres	100 m.	82.04
11	Loading to truck P.V.C. pipes of 300-200-160-140-110 mm dia 2 to 4 kg/cm <sup>2</sup> capacity and average length of 6 metre kept in telescopic arrangement and stacking in godown/site as per direction including carriage by headload within lead of 50 metres.	100 m.	101.84
12	Carriage of P.V.C. pipes of 300-200-160-140-110 mm dia 2 to 4 kg / cm <sup>2</sup> capacity and average length of 6 metre kept in telescopic arrangement over Pucca / Kancha road for every 100 m of such pipe upto 100 kilometre.	K.M.	8.25
13	Extra rate for carriage of P.V.C. pipes of 300-200-160-140-110 mm dia 2 to 4 kg / cm <sup>2</sup> capacity and average length of 6 metre kept in telescopic arrangement over Pucca / Kancha road for every 100m of such pipe beyond 100 kilometre upto any distance. Note: During loading, unloading and carriage,P.V.C. pipes are to be arranged telescopically. Measurements are to be taken for individual pipe. The portion of Kancha road should be converted to equivalent length of Pucca road by multiplying with 1.5 and rounding of 0.5 km.	K.M.	5.66
14	(A) Transportation of Submersible Electro Motor Pumping set along with all other accessories and equipments including bend, sluice valve, column pipes etc. from Sub-Divisional Store to worksite including loading at the lifting point and unloading at the delivery point including necessary head load upto 100 metre at both ends. (A) Carriage by road (a) Distance upto 50 km. (i) 100/150/200 cubic metre per hour (m <sup>3</sup> /hr) capacity electro motor pumping set with column pipes and accessories etc. (full set) (ii) 30 cubic meter per hour (m <sup>3</sup> /hr) capacity Electro motor pumping set.	Each set Each set	2,945.78 552.57
	(b) Additional distance for each 25 km. beyond 50 km. upto any distance. (i) 100/150/200 cubic metre per hour (m <sup>3</sup> /hr) capacity electro motor pumping set with column pipes and accessories etc. (ii) 30 cubic meter per hour (m <sup>3</sup> /hr) capacity electro Motor pumping set.	Each set Each set	221.59 44.32
	(B) Carriage by boat (i) 100/150/200 cubic metre per hour (m <sup>3</sup> /hr) capacity electro motor pumping set with column pipes and accessories etc. (full set) (ii) 30 cubic meter per hour (m <sup>3</sup> /hr) capacity Electro motor pumping set.	Each set Each set	2,945.78 552.57
	(b) Additional distance for each 25 km. beyond 50 km. upto any distance. (i) 100/150/200 cubic metre per hour (m <sup>3</sup> /hr) capacity electro motor pumping set with column pipes and accessories etc. (ii) 30 cubic meter per hour (m <sup>3</sup> /hr) capacity electro Motor pumping set.	Each set Each set	221.59 44.32
	(B) Transportation of centrifugal Pumping set of capacity 30 cubic meter per hour for S.T.W. with all other accessories and equipments including bend, sluice valve, column pipes etc. from Sub-Divisional Store to worksite including loading at the lifting point and unloading at the delivery point including necessary head load upto 100 metre at both ends. (A). Carriage by road		

KM

It. No.	Description of item	Unit	Basic Price in Rs
	(a) Distance upto 50 km.	Each set	552.57
	(b) Additional distance for each 25 km. beyond 50 km. upto any distance.	Each set	44.32
	(B) Carriage by boat		
	(a) Distance upto 50 K.M.	Each set	552.57
	(b) Additional distance for each 25 km. beyond 50 km. upto any distance.	Each set	44.32
15	Transportation of vertical turbine pump set and motor along with all other accessories and equipments including bend, sluice valve, bowl assembly, shaft, oil tube, column pipe, discharge head, bearing, coupling etc. including loading the same at lifting point and unloading the same at the delivery point including necessary head load upto 100 meter at both ends and stacking the same within the tubewell premises as per direction all complete.		
	(a) Distance upto 50 km.	Each set	3,498.34
	(b) Distance upto any length beyond 50 km. for each 25 km. or part thereof	Each set	295.14
16	a) Transportation of Diesel Engine pumping set / Electro-Motor pumping set for Major R.L.I. of any make/brand with necessary fixtures viz. M.S. bend, M.S. Pipes, Rubber Hose Pipe, Manifold, Surge tank, foot valve, non-return valve, tail piece, hose clamp, sluice valve, priming chamber etc. over Pucca/Kancha road from Sub-Divisional Store to worksite excluding loading at the lifting point and unloading at the delivery point.		
	A. For Diesel Engine		
	(a) Carriage by Road :		
	(i) Distance upto 50 km.	Each Set	2,731.73
	(ii) Distance beyond 50 K.M. for such additional 25 K.M. or part thereof.	Each Set	197.08
	(b) Carriage by Boat :		
	(i) Distance upto 25 km.	Each Set	2,731.73
	(ii) Distance beyond 25 km. for such additional 5 km or part thereof.	Each Set	197.08
	B. For Electro Motor		
	(a) Carriage by Road :		
	(i) Distance upto 50 km.	Each Set	1,964.16
	(ii) Distance beyond 50 km. for such additional 25 km. or part thereof.	Each Set	140.50
	(b) Carriage by Boat :		
	(i) Distance upto 25 km.	Each Set	1,964.16
	(ii) Distance beyond 25 km. for such additional 5 km. or part thereof.	Each Set	140.50
	b) Transportation of Diesel Engine pumping set / Electro-Motor pumping set for Midi R.L.I. of any make/brand with necessary fixtures viz. M.S. bend, M.S. Pipes, Rubber Hose Pipe, Manifold, Surge tank, foot valve, non-return valve, tail piece, hose clamp, sluice valve, priming chamber etc. over Pucca/Kancha road from Sub-Divisional Store to worksite excluding loading at the lifting point and unloading at the delivery point.		
	A. For Diesel Engine		
	(a) Carriage by Road :		
	(i) Distance upto 50 km.	Each Set	1,822.72
	(ii) Distance beyond 50 K.M. for such additional 25 K.M. or part thereof.	Each Set	129.18
	(b) Carriage by Boat :		
	(i) Distance upto 25 km.	Each Set	1,822.72
	(ii) Distance beyond 25 km. for such additional 5 km or part thereof.	Each Set	129.18
	B. For Electro Motor		
	(a) Carriage by Road :		
	(i) Distance upto 50 km.	Each Set	1,315.42
	(ii) Distance beyond 50 km. for such additional 25 km. or part thereof.	Each Set	95.24
	(b) Carriage by Boat :		
	(i) Distance upto 25 km.	Each Set	1,315.42
	(ii) Distance beyond 25 km. for such additional 5 km. or part thereof.	Each Set	95.24
	c) Transportation of Diesel Engine pumping set / Electro-Motor pumping set for Mini R.L.I. of any make/brand with necessary fixtures viz. M.S. bend, M.S. Pipes, Rubber Hose Pipe, Manifold, Surge tank, foot valve, non-return valve, tail piece, sluice valve, priming chamber etc. over Pucca / Kancha road from Sub-Divisional Store to worksite excluding loading at the lifting point and unloading at the delivery point.		

It. No.	Description of item	Unit	Basic Price in Rs
	A. For Diesel Engine (a) Carriage by Road : (i) Distance upto 50 km. (ii) Distance beyond 50 K.M. for such additional 25 K.M. or part thereof. (b) Carriage by Boat : (i) Distance upto 25 km. (ii) Distance beyond 25 km. for such additional 5 km or part thereof.	Each Set Each Set Each Set Each Set	1,367.28 96.18 1,367.28 96.18
	B. For Electro Motor (a) Carriage by Road : (i) Distance upto 50 km. (ii) Distance beyond 50 km. for such additional 25 km. or part thereof. (b) Carriage by Boat : (i) Distance upto 25 km. (ii) Distance beyond 25 km. for such additional 5 km. or part thereof.	Each Set Each Set Each Set Each Set	983.50 71.66 983.50 71.66
17	Carriage by road excluding, loading, unloading and stacking of diesel filled barrel of capacity 205 lits. or part thereof for the following distance. (i) Carriage over pucca road upto 50 km. distance. (ii) Extra rate beyond initial distance of 50 km. for each additional 25 km. or part.	Each Brrl. Each Brrl.	201.79 28.29
18	Carriage by boat excluding loading, unloading and stacking of Diesel filled barrel of capacity 205 litres or part thereof for the following distance . (i) Upto 20 km. distance (ii) Beyond 20 km. and upto 50 km. distance. (iii) Beyond 50 km. distance for each additional 25 km. or part.	Each Brrl. Each Brrl. Each Brrl.	81.09 100.90 20.74
19	Carriage by cart excluding loading, unloading and stacking of Diesel filled barrel of capacity 205 litres or part thereof for the following distance. (i) Upto 10 km. distance. (ii) Extra rate for carriage of diesel filled barrel beyond initial distance of 10 km. for each additional 1 km or part thereof.	Each Brrl. Each Brrl.	81.09 12.26
20	Loading of diesel filled barrel of capacity 205 lts. or part thereof into the following transport manually or by other mean. (i) Over Truck (ii) Over Boat (iii) Over Cart (the rates is inclusive of hire charges of necessary accessories and Tools & Plants)	Each Brrl. Each Brrl. Each Brrl.	8.49 9.43 4.71
21	Unloading of diesel filled barrel from the following transport and stacking the same as per direction (i) From Truck (ii) From Boat (iii) From Cart	Each Brrl. Each Brrl. Each Brrl.	3.77 8.49 2.83
22	Loading of Diesel Engine and pumping set of 200 cubic metre per hour (m <sup>3</sup> /hr) capacity of any make/brand with necessary accessories and fixtures namely M.S. Bend, M.S. Pipes, Rubber Hose, Manifold, Surge Tank, foot valve, non-return valve, sluice valve etc. by any means into the following transport at lifting point having lead of 100 metres and unloading the same at destination and stacking the materials properly at a distance not exceeding 100 metre complete as per direction of Engineer-in-Charge. (i) Truck (ii) Boat	Each set Each set	1,108.91 1,328.62
23	Loading of Electro Motor pumping set of any make of 200 cubic metres per hour (m <sup>3</sup> /hr) capacity with necessary accessories and fixtures viz. M.S. Bend, M.S. Pipes, Rubber Hose, Manifold, Surge Tank, Foot Valve, non-return valve, sluice valve etc. by any means into the following transport at lifting point having a lead of 100 metre and unloading the same at distination and stacking the same properly at a distance of about 100 metre complete as per direction of Engineer-in-Charge. (i) Truck (ii) Boat	Each set Each set	621.40 798.68

KM

It. No.	Description of item	Unit	Basic Price in Rs
24	Carriage of empty barrel of 205 litre capacity by pucca road including loading and stacking at the destination as per direction and head load upto 100 m. at both end. N.B. :- Rate for all items from Sl.No. 1 to 24, mentioned under this Chapter 8.00 under Heading "Carriage of Materials", covers and includes all cost of any ancillary construction of temporary roads over field and / or culverts, repairing of existing roads and / or culverts, carrying materials by head-load, cart or boat, associated with the works, if not specifically mentioned otherwise in the description of items.	Each Barrel / Km	1.89
25	i) Transportation of tripod set alongwith all other accessories & equipments including bend from Sub-divisional Store to work site including loading at the lifting point and unloading at the delivery point including head load upto 100 meter at both ends. A. Carriage by road / boat a) Distance upto 50 KM b) Additional distance for each 25 KM beyond 50 KM upto each set. ii) Transportation of Quadruiped set alongwith all other accessories & equipments including bend from Sub-divisional Store to work site including loading at the lifting point and unloading at the delivery point including head load upto 100 meter at both ends. A. Carriage by road / boat a) Distance upto 50 KM b) Additional distance for each 25 KM beyond 50 KM upto each set.	Each set Each set	1,559.64 156.53
26	Carriage of Departmental materials from the Departmental Store to the work site and return back the damaged/replaced and unused materials to store including loading & unloading complete at both sides by Tempo/Van Rikshaw/Mini Truck etc. upto 25 Km distance in one way. i) For Delivery pipe, Surge Tank, Bend, Valve etc. ii) For Kiosk Box iii) Pump-Motor Set (this item is applicable only for burnt/damaged Pump-Motor Set)	Each set Each set Each set	905.23 678.92 1,037.25
<b>Carriage of UPVC Tubewell Pipes</b>			
27	Labour for loading the following materials into trucks, carts, boats etc. at lifting point and unloading the materials at the destination and stacking the same as per direction including carriage by head load upto a lead of 100 metres at each end. uPVC Pipe/Ribbed Screen/Slotted Pipes i) 350 mm. DN dia. ii) 300 mm. DN dia. iii) 250 mm. DN dia. iv) 200 mm. DN dia. v) 150 mm. DN dia. vi) 100 mm. DN dia. vii) 75 mm. / 80 mm. DN dia.	Metre Metre Metre Metre Metre Metre Metre	13.77 12.82 10.37 6.98 4.71 3.68 2.64
28	Carriage of miscellaneous materials over pucca road upto 5 km. distance uPVC Pipe/Ribbed Screen/Slotted Pipes i) 350 mm. DN dia. ii) 300 mm. DN dia. iii) 250 mm. DN dia. iv) 200 mm. DN dia. v) 150 mm. DN dia. vi) 100 mm. DN dia. vii) 75 mm. / 80 mm. DN dia.	Metre Metre Metre Metre Metre Metre Metre	11.22 4.71 6.93 5.61 4.29 3.96 3.63
29	Carriage of miscellaneous materials over pucca road Beyond 5 km. upto any distance uPVC Pipe/Ribbed Screen/Slotted Pipes (i) For carriage of 350 mm DN Beyond 5 km and upto 50 km From 50 km upto any distance	100m/ Km 100m/ Km	27.39 16.50

KM

It. No.	Description of item	Unit	Basic Price in Rs
	(ii) For carriage of 300 mm DN Beyond 5 km and upto 50 km From 50 km upto any distance	100m/ Km	21.78
	(iii) For carriage of 250 mm DN Beyond 5 km and upto 50 km From 50 km upto any distance	100m/ Km	13.70
	(iv) For carriage of 200 mm DN Beyond 5 km and upto 50 km From 50 km upto any distance	100m/ Km	19.14
	(v) For carriage of 150 mm DN Beyond 5 km and upto 50 km From 50 km upto any distance	100m/ Km	10.89
	(vi) For carriage of 100 mm DN Beyond 5 km and upto 50 km From 50 km upto any distance	100m/ Km	16.50
	(vii) For carriage of 75/80 mm DN Beyond 5 km and upto 50 km From 50 km upto any distance	100m/ Km	8.25
		100m/ Km	13.70
		100m/ Km	8.25
		100m/ Km	12.30
		100m/ Km	7.35
		100m/ Km	10.89
		100m/ Km	6.44

AM  
/

## 9.00 MISCELLANEOUS ITEMS

### 9.00 MAINTENANCE OF PIPE LINE, DRILLING OF TUBE WELLS, INSTALLATION & WITHDRAWALS AND ELECTRICAL ITEMS

It. No.	Description of item	Unit	Basic Price in Rs
<b>MAINTENANCE OF PIPE LINE</b>			
1	a) Removing of Chokage due to sludge, mud, sand or any other forign materials deposition from the underground 110 / 140 / 200 / 315 mm dia. P.V.C. Pipe Line with split bamboo,wire brush, coir rope etc. along with suitable cleaning agent as necessary as per direction of E.I.C. (This item includes the cost of earth cutting & back filling of trenches and required materials for chokage cleaning but excluding the cost for replacement & jointing of PVC pipes). i) For 315 mm dia PVC Pipe ii) For 200/140/110 mm dia PVC Pipe	Metre Metre	35.83 31.12
2	b) Removing of Chokage due to sludge, mud, sand or any other forign materials deposition from the underground 450 / 300 / 225/ 150 mm dia. R.C.C. Pipe Line with split bamboo, wire brush, coir rope etc. along with suitable cleaning agent as necessary as per direction of E.I.C. (This item includes cost of earth cutting & back filling of trenches and required materials for cleaning but excluding the cost for taking out 1 full length of RCC Pipe by dismantling of 2 nos. of Collars & re-fitting the RCC pipe with new two nos. collar). i) For 450 mm dia. RCC Pipe ii) For 300 mm dia. RCC Pipe iii) For 225 mm dia. RCC Pipe iv) For 150 mm dia. RCC Pipe	Metre Metre Metre Metre	46.20 44.32 38.66 35.83
<b>INSTALLATION &amp; WITHDRAWALS OF PIPE LINE ACCESSORIES</b>			
3	Dismantling the existing G.I./M.S. Delivery Pipe line connection between the existing D.C./Surge Tank/Tripod Set & Tube Well assembly viz Sluice valve, Bend, Surge Tank/Distribution Chamber /Tripod Set Connection pipe etc.and disconnection of delivery side viz. Special bend etc. all complete as per direction of the E.I.C. and stacking all serviceable materials at site.	Each set	752.47
4	Supplying, fitting & fixing of M.S. plate of size 40 cm x 40 cm, thickness 6 mm, consisting of two equal halves (40cm x 20cm), placed over Housing Pipe of HDTW/ MDTW to rest the supporting clamps, with semi circular hole of 170 mm dia. at centre including locking arrangement between the two halves on both sides, including fitting, fixing of 40 mm dia. G.I. bend by making a hole on plate for passing submersible cable smoothly and complete in all respect.	Each set	897.69
5	Supplying, fitting & fixing of M.S. plate of size 20 cm x 20 cm, thickness 6 mm, make of two halves (20cm x 10 cm), placed over Housing Pipe of LDTW to rest the supporting clamps,with semi circular hole of 90 mm dia. at centre including locking arrangement between the two halves on both sides,including fitting, fixing of 25 mm dia. G.I. bend by making a hole on plate for passing submersible cable smoothly and complete in all respect.	Each set	382.84
6	Supplying, fitting & fixing of PVC pipes & fittings (medium duty) conforming to IS:12818/ASTMD -1785 and threaded to match with GI Pipes as per IS : 1239 (Part - I). Nipple (300 mm long) i) 80 mm dia. ii) 100 mm dia. iii) 150 mm dia.	Each Each Each	245.17 392.27 476.19
7	Supplying, fitting & fixing of 150 mm dia ISI marked G.I. Short pipe (medium quality) of suitable length (0.60m to 1.0m) with both end screwed, one end to match with the 150 mm dia PVC Housing Pipe and other end match with the 150 mm dia MS top cap as per direction of the E.I.C.	Metre	1,430.46

It. No.	Description of item	Unit	Basic Price in Rs
<b>ELECTRICAL ITEMS</b>			
8	Supplying, fitting & fixing 350 mm x 250 mm x 25 mm size Wooden Plank on wall (for fitting & fixing of electrical equipments as necessary on the plank).	Each	413.01
9	Supplying, fitting & fixing of 32 Amps / 63 Amps / 100 Amps, 415V rewirable type porcelain body Fuse top & base complete set conforming to IS: 13947/Part-4/Sec-I/1993 over wooden plank/ board on wall and making necessary connection with the electrical cable as per direction of the E.I.C. i) 32 Amps ii) 63 Amps iii) 100 Amps iv) 200 Amps	Set Set Set Set	281.94 572.37 737.39 1,337.10
10	Fitting & fixing of Pump Controller (upto 7.5 HP capacity) of Size 450 mm x 350 mm x 200 mm with Nuts & Bolts fixed on M.S. Clamps (4 nos. 250 mm to 350 mm long, 500 mm width, 6 mm thick, L-shaped) on wall and making necessary connection with the electrical cables.	Each	247.05
11	Fitting & fixing of Pump Controller (12.5 HP to 25 HP capacity) of size 950 mm x 1000 mm x 450 mm over iron legs (600 mm height) on floor with 150 mm thick Cement Concrete (4:2:1) block and making necessary connection with the electrical cables as per direction of the E.I.C. (excluding cost of Cement Concrete) i) 12.5 HP & up to 15 HP ii) Above 15 HP & up to 20 HP iii) Above 20 HP & up to 25 HP	Each Each Each	407.35 523.34 630.83
12	Fitting & fixing of Starter (Direct on Line or Star-Delta/Auto-Transformer) with Nuts & Bolts fixed on Angle iron frame on wall and making necessary connection with the electrical cables. i) Direct on line Starter upto 5 HP ii) Star-Delta / Auto-Transformer Starter (Above 5 HP upto 15 HP) iii) Star-Delta / Auto-Transformer Starter (Above 15 HP upto 25 HP)	Each Each Each	PWD PWD 240.45
13	Meter loop connection with 1.1 K.V. Gr. 3½ core / 4 core 10 Sqmm to 50 Sq mm. P.V.C./ XLPE insulated & sheathed and armoured Aluminium/Copper Cable from Meter to incoming TPN Main Switch / Terminal. (Brand: Gloster/Havells/Finolex) a) For LDTW Scheme i) 10 Sqmm 4 Core Aluminium Cable ii) 10 Sqmm 4 Core Copper Cable b) For HDTW/MDTW/MINI RLI Scheme i) 25 Sqmm 3½ Core Aluminium Cable ii) 25 Sqmm 3½ Core Copper Cable c) For MIDI RLI Scheme i) 35 Sqmm 3½ Core Aluminium Cable d) For MAJOR RLI Scheme i) 50 Sqmm 3½ Core Aluminium Cable	Metre Metre Metre Metre Metre Metre	245.17 764.73 330.03 1,559.64 392.27 486.56
14	Supplying and Drawing with 1.1 KV, PVC flexible 'FR' cables copper conductor conforming to IS 694 in suitable size with fitting and fixing on wall/Kiosk Box, including making necessary connection to the pre-fixed devices with all necessary accessories like saddle, screw, clips, gland, socket etc. conforming to IEE regulation and as per direction of EIC. (Brand: Gloster/Havells/Finolex) [a] For Major RLI (i) 4Cx 25 sqmm Copper cable conforming to IS 694 in [100/200 A TPN switch to Bus-bar] (ii) 3C X 16 sqmm copper cable conforming to IS 694 [Busbar to 63 A, TP Main switch and 63 A TP switch to Motor starter] (iii) 2 X 3C X 10 sqmm copper cable conforming to IS 694 in 32 mm GI conduit (ISI-Medium quality) [Star-Delta Motor starter to Motor]	Metre Metre Metre	1,561.53 793.96 926.92

KM



It. No.	Description of item	Unit	Basic Price in Rs
	[b] For Midi RLI		
	(i) 4Cx 16 sqmm Copper cable conforming to IS 694 in [63 A TPN switch to Busbar]	Metre	1,028.76
	(ii) 3C X 10 sqmm copper cable conforming to IS 694 [Busbar to 32 A, TP Main switch and 32 A TP switch to Motor starter]	Metre	558.23
	(iii) 2 X 3C X 4 sqmm copper cable conforming to IS 694 in 32 mm GI conduit (ISI-Medium quality)	Metre	532.77
	<b>[ Star-Delta Motor starter to Motor]</b>		
	[c] For Mini RLI		
	(i) 4Cx 10 sqmm Copper cable conforming to IS 694 in [63 A TPN switch to Busbar]	Metre	712.87
	(ii) 3C X 4 sqmm copper cable conforming to IS 694 [Busbar to 32 A, TP Main switch and 32 A TP switch to Motor starter]	Metre	280.06
	(iii) 2 X 3C X 2.5 sqmm copper cable conforming to IS 694 in 25 mm GI conduit (ISI-Medium quality)	Metre	394.15
	<b>[ Star-Delta Motor starter to Motor]</b>		
15	Insulation testing of internal wiring of Pump House/Kiosk Box including wiring of electric Motor & other ancillary equipments by means of Megger	LS	165.02
16	Repairing of Manually Operated Heavy Duty Star/Delta Oil Immersed <b>Starters</b> by taking out and fitting fixing <b>Overload Coil</b> (to be supplied departmentally) with testing as per direction of the Engineer-in-Charge. (For 100Amp/63Amp)	Each	103.72
17	Repairing of Manually Operated Heavy Duty Star/Delta Oil Immersed <b>Starters</b> by taking out and fitting fixing <b>No Volt Coil</b> (to be supplied departmentally) with testing as per direction of the Engineer-in-Charge. (For 100Amp/63Amp)	Each	103.72
18	Repairing of Manually Operated Heavy Duty Star/Delta Oil Immersed <b>Starters</b> by taking out and fitting fixing <b>Sets of Contact</b> (to be supplied departmentally) with testing as per direction of the Engineer-in-Charge. (For 100Amp/63Amp)	Each	132.01
19	Repairing of <b>Main Switch</b> For 63 Amps/32 Amps (REWIREABLE TYPE) by taking out and fitting fixing <b>Fuse Grip</b> (63 Amps/32 Amps) (to be supplied departmentally) as per direction of the Engineer-in-Charge.	Each	52.81
20	Repairing of <b>Main Switch</b> For 63 Amps/32 Amps (REWIREABLE TYPE) by taking out and fitting fixing <b>Action Bar with U-Clip setting</b> (to be supplied departmentally) with testing as per direction of the Engineer-in-Charge.	Each	103.72
21	Repairing of <b>Main Switch</b> For 63 Amps/32 Amps (REWIREABLE TYPE) by taking out and fitting fixing <b>End Shield Block with connecting wire</b> (to be supplied departmentally) as per direction of the Engineer-in-Charge.	Each	103.72
22	Repairing of wedge of <b>T.P./N.T.P./Alfa Alfa valve</b> by taking out old bush and fitting, fixing with supply of new Gunmetal Bush (1"), Rubber Pad and M.S.Ring etc. complete as per sample and as per direction of the Engineer-in-Charge. 150 mm nominal size	Each	133.90
23	Repairing of <b>T.P./N.T.P./Alfa Alfa Valve</b> with required wedge, spindle, top cover plate etc. (to be supplied departmentally) including machining, boring and painting etc. as per direction of the Engineer-in-Charge. 150 mm nominal size	Each	86.75
24	Removing of rust & other foreign materials from the surface of 150 mm nominal size <b>T.P./N.T.P./Alfa Alfa valve</b> by scrubber, washing thoroughly, greasing, applying one coat of Red lead primer & two coats of Black Japan Paint over the valve, complete in all respect as per direction.	Each	47.15
25	Repairing of <b>Sluice Valve</b> with required wedge, spindle, catcher, top cover plate etc. (to be supplied departmentally) including fitting fixing as per direction of Engineer-in-Charge. i) 150 mm dia. ii) 125 mm dia. iii) 80 mm dia.	Each Each Each	103.72 94.30 75.44

It. No.	Description of item	Unit	Basic Price in Rs
26	Supppying, fitting and fixing of <b>150 mm heavy duty supporting clamps</b> in two halves made of M.S. flat for holding 150 mm N.B. Column pipe, thickness of the clamp 12 mm, width of the clamp 150 mm, extended length of the arm 200 mm, space between rows 100 mm, space between bolts in a row 75 mm, equally spaced from the centre line of the arm, dia of bolt 16 mm. The gap between arms of clamp and pipe assembly before tightening should be between 6 mm to 10 mm. Two rows of bolts of two nos in each rows of 16 mm size shall be provided on either side of the clamp, in other words there will be all together 4 rows of bolts with the provisions of 8 nos of bolts with nuts and with spring and flat washer.	Each Set	1,578.50
27	Supppying, fitting and fixing of <b>125 mm heavy duty supporting clamps</b> in two halves made of M.S. flat for holding 125 mm N.B. Column pipe, thickness of the clamp 12 mm, width of the clamp 150 mm, extended length of the arm 200 mm, space between rows 100 mm, space between bolts in a row 75 mm, equally spaced from the centre line of the arm, dia of bolt 16 mm. The gap between arms of clamp and pipe assembly before tightening should be between 6 mm to 10 mm. Two rows of bolts of two nos in each rows of 16 mm size shall be provided on either side of the clamp, in other words there will be all together 4 rows of bolts with the provisions of 8 nos of bolts with nuts and with spring and flat washer.	Each Set	1,448.37
28	Supppying, fitting and fixing of <b>80 mm NB heavy duty Supporting Clamps</b> in two halves made of MS flats for holding 80 mm NB Column Pipes, thickness of the clamp 10 mm, width of the clamp 75 mm, extended length of the arm 150 mm, space between adjacent holes in either side of the extended arm 75 mm, equally spaced from the centre line of the arm, dia of bolt 16 mm. The gap between arms of clamp and pipe assembly before tightening should be between 6 mm to 10 mm. Two nos. of bolt of 16 mm size shall be provided on either side of the clamp, in other words there will be all together 2 rows of bolt with the provisions of 4 nos. of bolt with nuts and with spring and flat washer.	Each Set	848.66

KM

**10.00 Earth work in excavation for WDS / WHS / RESERVOIR / SFMIS etc**

It. No.	Description of item	Unit	Basic Price in Rs
1	Excavation in ordinary soil / mixed soil i.e. clay mixed with moorum, kankar, pebbles / silt dry or moist / slushy silt / sticky soil for WDS / WHS / RESERVOIR / SFMIS etc with hydraulic excavator of required bucket capacity including cutting and loading in tippers, trimming bottom and side slopes in accordance with requirement of lines, grades and cross section and transporting to embankment/ disposal site within all lifts and lead upto 1500 m including spreading, leveliing disposed spoils at disposed area. (mode of measurement: pre work and post work)	Cu.M.	60.35
2	Excavation in gravel / moorum / kankar / compact moorum / very much weathered rock / sticky soil mixed with moorum or ghooting for WDS / WHS / RESERVOIR / SFMIS etc with hydraulic excavator of required bucket capacity including cutting and loading in tippers, trimming bottom and side slopes in accordance with requirement of lines, grades and cross section and transporting to embankment/ disposal site within all lifts and lead upto 1500 m including spreading, leveliing disposed spoils at disposed area. ( mode of measurement: pre work and post work)	Cu.M.	69.78
3	Excavation in soft weather rock / solt laterite rocks for WDS / WHS / RESERVOIR / SFMIS etc with hydraulic excavator of required bucket capacity including cutting and loading in tippers, trimming bottom and side slopes in accordance with requirement of lines, grades and cross section and transporting to embankment/ disposal site within all lifts and lead upto 1500 m including spreading, leveliing disposed spoils at disposed area. (mode of measurement: pre work and post work)	Cu.M.	82.98
4	Extra rate for each additional km or part thereof above the initial lead of 1.5 km on items no 1, 2 & 3	Cu.M.	13.20
5	Extra rate where land is to be arranged by the contractor on items no 1, 2 & 3 for disposal of spoils.	Cu.M.	7.54

*Handwritten mark*

## 11.00 MICRO IRRIGATION SYSTEM (SPRINKLER AND DRIP)

It. No.	Description of item	Unit	Basic Price in Rs
	<b>VALVES</b>		
1	<b>Supplying , fitting and fixing of By -Pass Assembly of approved make and quality all complete as per direction of Engineer in- Charge.</b>		
	i G.I. BYPASS & ARV M/F 1.5"X1.5X1"	No	304.57
	ii G.I. BYPASS & ARV M/F 2"X1.5"X1"	No	393.21
	iii G.I. BYPASS&ARV M/F 2.5"X1.5"X1"	No	420.56
	iv G.I. BYPASS & ARV M/F 3"X1.5"X1"	No	556.34
2	<b>Supplying , fitting and fixing of PP Header Assemblies of approved make and quality, all complete as per direction of Engineer in -charge.</b>		
	i Header Asly-2" with PVC Ball valve & Port for 3/4" Ventury.	No	2645.92
	ii Header Asly-2" with PVC Ball valve & Port for 1" Ventury.	No	2645.92
	iii Header Asly-2.5" with PVC Ball valve & Port for 1 & 2" Ventury.	No	4163.12
	iv Header Asly-3" with PVC Ball valve & Port for 1 & 2 " Ventury	No	5854.78
3	<b>Supplying , fitting and fixing of CI Non Return Valve as per IS:5312</b>		
	i C. I NON RETURN VALVE 1.5"	No	2498.82
	ii C. I. NON RETURN VALVE 2"	No	6701.55
	iii C. I. NON RETURN VALVE 2.5"	No	7674.67
	iv C. I. NON RETURN VALVE 3"	No	9277.69
4	<b>Supplying , fitting and fixing of PVC Non Return Valve as per IS:10805</b>		
	i PVC Non Return Valve 32 mm	No	272.51
	ii PVC Non Return Valve 40 mm	No	382.84
	iii PVC Non Return Valve 50 mm	No	486.56
	iv PVC Non Return Valve 63 mm	No	578.97
	v PVC Non Return Valve 75 mm	No	740.22
	vi PVC Non Return Valve 90 mm	No	1643.56
5	<b>Supplying , fitting and fixing of Air Release Cum Vacuum Breaker Valve of approved make and quality all complete as per direction of Engineer-in-Charge.</b>		
	i PVC AIR RELEASE VALVE MINI 1/2 "	No	90.52
	ii PVC AIR RELEASE VALVE MINI 3/4 "	No	104.67
	iii PVC AIR RELEASE VALVE MINI 1 "	No	120.70
	iv DOUBLE ACT AIR/VACUUM RELEASE VALVE 1"	No	670.44
	v DOUBLE ACT AIR/VACUUM RELEASE VALVE 2"	No	1746.34
6	<b>Supplying , fitting and fixing of G.M. Gate Valve/ Throttle Valve as per IS:778.</b>		
	i BUTTERFLY VALVE C.I. 40 MM - 1.5"	No	2371.52
	ii BUTTERFLY VALVE C.I. 50 MM - 2"	No	2583.68
	iii BUTTERFLY VALVE C.I. 65 MM -2.5"	No	2992.92
	iv BUTTERFLY VALVE C.I. 80 MM -3"	No	3165.48
	v G. M. Valve 1/2"	No	738.33
	vi G. M. Valve 3/4"	No	967.47
	vii G. M. Valve 1"	No	1272.98
	viii G. M. Valve 1 - 1/4"	No	2117.87
	ix G. M. Valve 1 - 1/2"	No	2430.93
	x G. M. Valve 2"	No	3082.50
	xi G. M. Valve 2 - 1/2"	No	5067.41
	xii G. M. Valve 3"	No	7462.51
7	<b>Supplying , fitting and fixing of PVC Control Valve of approved make and quality all complete as per direction of Engineer-in-Charge.</b>		

AM

It. No.		Description of item	Unit	Basic Price in Rs
	i	PVC Control Valve 25 mm	No	231.97
	ii	PVC Control Valve 32 mm	No	331.92
	iii	PVC Control Valve 40 mm	No	462.05
	iv	PVC Control Valve 50 mm	No	580.86
	v	PVC Control Valve 63 mm	No	912.78
	vi	PVC Control Valve 75 mm	No	1236.21
	vii	PVC Control Valve 90 mm	No	2336.63
8		<b>Supplying , fitting and fixing of PVC Flush Valve of approved make and quality all complete as per direction of Engineer-in-charge</b>		
	i	Flush Valve 40 mm	No	73.55
	ii	Flush Valve 50 mm	No	93.35
	iii	Flush Valve 63 mm	No	99.95
	iv	Flush Valve 75 mm	No	139.56
	v	Flush Valve 90 mm	No	187.65
9		<b>Supplying , fitting and fixing of Pressure Gauge &amp; Acessories of approved make and quality all complete as per direction of Engineer in charge</b>		
	i	Pressure Gauge 2" Dial	No	231.02
	ii	PG2 WITH P.G. ADAPTOR 1/4" FEMALE THR	No	246.11
	iii	Pressure Gauge Glycerin Filled 2" Dial	No	549.74
	iv	PGGF2 WITH P.G. ADAPTOR 1/4" FEMALE THR	No	569.54
	v	Pressure Gauge Cock 1/8" x 1/8"	No	112.21
	vi	Pressure Gauge Cock 1/4" x 1/8"	No	125.41
<b>Filtration &amp; Fertigation</b>				
1		<b>Supplying , fitting and fixing of Hydrocyclone Filter as per IS:14743</b>		
	i	Hydrocyclone Separator 25 m <sup>3</sup> /hr, 2"	No	7937.75
	ii	Hydrocyclone Separator 40 m <sup>3</sup> /hr, 2.5"	No	9721.81
	iii	Hydrocyclone Separator 50 m <sup>3</sup> /hr, 3"	No	20930.66
2		<b>Supplying , fitting and fixing of Sand Filter - Manual as per IS:14606</b>		
	i	Sand Filter 10m <sup>3</sup> /hr-M Single	No	17192.81
	ii	Sand Filter 20m <sup>3</sup> /hr-M Single	No	18483.71
	iii	Sand Filter 25 m <sup>3</sup> /hr-M, 2" Single With M.MF	No	27029.66
	iv	Sand Filter 40 m <sup>3</sup> /hr-M, 2.5" Single With M.MF.	No	34875.95
	v	Sand Filter 50 m <sup>3</sup> /hr-M, 3" Single With M.MF.	No	52948.53
3		<b>Screen Filter (IS:12785-1994)</b>		
3.1		<b>Supplying , fitting and fixing of Screen Filter Plastic Body as per IS:12785</b>		
	i	Screen Filter 7m <sup>3</sup> /hr, 1"	No	300.80
	ii	Screen Filter 12m <sup>3</sup> /hr, 1.5"	No	2121.64
	iii	Screen Filter 20-25m <sup>3</sup> /hr, 2"	No	3512.49
	iv	Screen Filter 40m <sup>3</sup> /hr, 2.5"	No	3658.65
	v	Screen Filter 40-50m <sup>3</sup> /hr, 3"	No	4284.76
3.2		<b>Supplying , fitting and fixing of Screen Filter Metal Body as per IS:12785</b>		
	i	Metal Screen Filter 10 m <sup>3</sup> /hr, 2"	No	2484.67
	ii	Metal Screen Filter 20 m <sup>3</sup> /hr, 2"	No	3452.14
	iii	Metal Screen Filter 30 m <sup>3</sup> /hr, 2.5'	No	3452.14
	iv	Metal Screen Filter 40 m <sup>3</sup> /hr, 3"	No	6252.70
3.3		<b>Supplying , fitting and fixing of Disc Clean Filter Plastic Body as per IS:12785</b>		
	i	Disc Clean Filter 7m <sup>3</sup> /hr, 1"	No	1699.20
	ii	Disc Clean Filter 12m <sup>3</sup> /hr, 1.5"	No	3934.93
	iii	Disc Clean Filter 20 -25 m <sup>3</sup> /hr, 2"	No	5173.02
	iv	Disc Clean Filter 30 m <sup>3</sup> /hr, 2.5	No	6069.77

KM

It. No.	Description of item	Unit	Basic Price in Rs
v	Disc Clean Filter 40m <sup>3</sup> /hr, 2.5"	No	7444.59
vi	Disc Clean Filter 40-50m <sup>3</sup> /hr, 3"	No	8181.98
4	<b>Fertigation Unit</b>		
4.1	<b>Supplying , fitting and fixing of Ventury as per IS:14483- Part I</b>		
i	Ventury Assembly Complete 3/4" Plastic	No	1106.08
ii	Ventury Assembly Complete 1" Plastic	No	2848.65
iii	Ventury Assembly Complete 1.25" Plastic	No	3783.12
iv	Ventury Assembly Complete 1.5" Plastic	No	5239.03
v	Ventury Assembly Complete 2" Plastic	No	7212.62
4.2	<b>Supplying , fitting and fixing of Ventury Manifold Metal of approved make and quality all complete as per direction of Engineer in Charge</b>		
i	Manifold GI + GMV 1.5" x 3/4"	No	2208.39
ii	Manifold GI + GMV 2" x 3/4"	No	4376.23
iii	Manifold GI + GMV 2.5" x 3/4"	No	7026.86
iv	Manifold GI + GMV 3" x 3/4"	No	10258.35
v	Manifold GI + GMV 2" x 1"	No	4716.64
vi	Manifold GI + GMV 2" x 1.¼"	No	4832.62
vii	Manifold GI + GMV 2" x 1½"	No	8183.86
viii	Manifold GI + GMV 2.5" x 1"	No	7234.31
ix	Manifold GI + GMV 2.5" x 1.¼"	No	7449.31
x	Manifold GI + GMV 2.5" x 1½"	No	11133.41
xi	Manifold GI + GMV 3" x 1"	No	10333.79
xii	Manifold GI + GMV 3" x 1.¼"	No	10951.42
xiii	Manifold GI + GMV 3" x 1½"	No	14275.32
xiv	Manifold GI + GMV 3" x 2"	No	14677.02
4.3	<b>Supplying , fitting and fixing of Fertigation Tank of approved make and quality all complete as per direction of Engineer in Charge.</b>		
i	30 LITER FERTIGATION EQUIPMENT	No	9497.39
ii	60 LITER FERTIGATION EQUIPMENT	No	12501.63
iii	90 LITER FERTIGATION EQUIPMENT	No	13848.16
iv	120 LITER FERTIGATION EQUIPMENT	No	15547.36
v	160 LITER FERTIGATION EQUIPMENT	No	17470.03
<b>uPVC Pipe for Agriculture</b>			
1	<b>Supplying , fitting and fixing of Socketed PVC Pipe 6 meter as per IS:4985</b>		
i	PVC pipe 32 mm x 10 kgf/cm <sup>2</sup>	Metre	41.49
ii	PVC pipe 40 mm x 06 kgf/cm <sup>2</sup>	Metre	42.43
iii	PVC pipe 40 mm x 10 kgf/cm <sup>2</sup>	Metre	64.12
iv	PVC pipe 50 mm x 06 kgf/cm <sup>2</sup>	Metre	62.23
v	PVC pipe 50 mm x 10 kgf/cm <sup>2</sup>	Metre	101.84
vi	PVC pipe 63 mm x 04 kgf/cm <sup>2</sup>	Metre	66.01
vii	PVC pipe 63 mm x 06 kgf/cm <sup>2</sup>	Metre	96.18
viii	PVC pipe 63 mm x 10 kgf/cm <sup>2</sup>	Metre	158.42
ix	PVC pipe 75 mm x 04 kgf/cm <sup>2</sup>	Metre	94.30
x	PVC pipe 75 mm x 06 kgf/cm <sup>2</sup>	Metre	135.78
xi	PVC pipe 75 mm x 10 kgf/cm <sup>2</sup>	Metre	226.31
xii	PVC pipe 90 mm x 04 kgf/cm <sup>2</sup>	Metre	132.96
xiii	PVC pipe 90 mm x 06 kgf/cm <sup>2</sup>	Metre	194.25
xiv	PVC pipe 90 mm x 10 kgf/cm <sup>2</sup>	Metre	323.43
<b>HDPE Pipe</b>			
1	<b>Supplying , fittings &amp; fixing of HDPE Pipes Grade -PE 80 (PN- 6.0)</b>		
i	75 mm OD	Metre	361.15

It. No.	Description of item	Unit	Basic Price in Rs
ii	90 mm OD	Metre	455.44
iii	110 mm OD	Metre	589.34
iv	125 mm OD	Metre	713.81
v	140 mm OD	Metre	855.26
vi	160 mm OD	Metre	1070.25
vii	180 mm OD	Metre	1305.99
viii	200 mm OD	Metre	1577.56
ix	225 mm OD	Metre	1945.31
2	<b>Supplying , fittings &amp; fixing of HDPE Pipes Grade -PE 80 (PN-10.0 as per IS: 4984.</b>		
i	75 mm OD	Metre	469.59
ii	90 mm OD	Metre	612.92
iii	110 mm OD	Metre	826.02
iv	125 mm OD	Metre	1028.76
v	140 mm OD	Metre	1251.29
vi	160 mm OD	Metre	1585.10
vii	180 mm OD	Metre	1960.39
viii	200 mm OD	Metre	2378.12
ix	225 mm OD	Metre	2982.55
<b>PVC Fittings</b>			
1	<b>SUPPLYING, FITTINGS &amp; FIXING OF PVC HD MOULDED COUPLER AS PER IS 7834 (HIGH DENSITY)</b>		
i	HD-Moulded Coupler 20 mm	No	10.37
ii	HD-Moulded Coupler 25 mm	No	15.09
iii	HD-Moulded Coupler 32 mm	No	16.97
iv	HD-Moulded Coupler 40 mm	No	28.29
v	HD-Moulded Coupler 50 mm	No	46.20
vi	HD-Moulded Coupler 63 mm	No	89.58
vii	HD-Moulded Coupler 75 mm	No	115.04
viii	HD-Moulded Coupler 90 mm	No	181.05
ix	HD-Moulded Coupler 110 mm	No	273.46
x	HD-Moulded Coupler 125 mm	No	323.43
2	<b>SUPPLYING, FITTINGS &amp; FIXING OF PVC HD-COMBINATION HD Female Threaded ADAPTER AS PER IS 7834 (HIGH DENSITY)</b>		
i	HD-Comb Female Thr. Adapter 25/32x3/4"F	No	19.80
ii	HD-Comb Female Thr. Adapter 25/32x1"F	No	24.52
iii	HD-Comb Female Thr. Adapter 32/40x1"F	No	36.78
iv	HD-Comb Female Thr. Adapter 32/40x1.25"F	No	38.66
v	HD-Comb Female Thr. Adapter 40/50x1.5"F	No	40.55
vi	HD-Comb Female Thr. Adapter 50/63x1.5"F	No	50.92
vii	HD-Comb Female Thr. Adapter 50/63X2"	No	60.35
viii	HD-Comb Female Thr. Adapter 63/75x2"F	No	66.95
ix	HD-Comb Female Thr. Adapter 63/75x2-1/2"F	No	84.87
x	HD-Comb Female Thr. Adapter 75/90x2.1/2"F	No	131.07
xi	HD-Comb Female Thr. Adapter 90/110x4"F	No	252.71
3	<b>SUPPLYING, FITTINGS &amp; FIXING OF PVC HD-COMBIINATION HD-MALE THREADED ADAPTER AS PER IS 7834 (HIGH DENSITY)</b>		
i	HD-Comb Male Thr. Adapter 20/25x1/2"M	No	5.66
ii	HD-Comb Male Thr. Adapter 20/25x3/4"M	No	7.54
iii	HD-Comb Male Thr. Adapter 25/32x1/2"M	No	9.43
iv	HD-Comb Male Thr. Adapter 25/32x3/4"M	No	10.37
v	HD-Comb Male Thr. Adapter 32/40x1 1/4"M	No	20.74

It. No.	Description of item	Unit	Basic Price in Rs
	vi HD-Comb Male Thr. Adapter 40/50x1 -1/4"M	No	33.00
	vii HD-Comb Male Thr. Adapter 40/50x1 -1/2"M	No	33.00
	viii HD-Comb Male Thr. Adapter 50/63x1 1/4"M	No	42.43
	ix HD-Comb Male Thr. Adapter 50/63x1 -1/2"M	No	44.32
	x HD-Comb Male Thr. Adapter 50/63 x 2" M	No	49.03
	xi HD-Comb Male Thr. Adapter 63/75 x 2" M	No	66.95
4	<b>SUPPLYING, FITTINGS &amp; FIXING OF SUPPLING, FITTINGS &amp; FIXING OF PVC HD-ELBOW (EQUAL) AS PER IS:7834</b>		
	i HD-Elbow (Equal) 20 mm 90°	No	6.60
	ii HD-Elbow (Equal) 25 mm 90°	No	10.37
	iii HD-Elbow (Equal) 32 mm 90°	No	14.14
	iv HD-Elbow (Equal) 40 mm 90°	No	30.17
	v HD-Elbow (Equal) 50 mm 90°	No	49.03
	vi HD-Elbow (Equal) 63 mm 90°	No	73.55
	vii HD-Elbow (Equal) 75 mm 90°	No	139.56
	viii HD-Elbow (Equal) 90 mm 90°	No	232.91
	ix HD-Elbow (Equal) 110 mm 90°	No	475.25
	x HD-Elbow (Equal) 125 mm 90°	No	627.06
	xi HD-Elbow (Equal) 140 mm 90°	No	607.26
	xii HD-Elbow (Equal) 160 mm 90°	No	780.76
	xiii HD-Elbow (Equal) 180 mm 90°	No	960.87
	xiv HD-Elbow (Equal) 200 mm 90°	No	1517.21
	xv HD-Elbow (Equal) 20 mm 45°	No	9.43
	xvi HD-Elbow (Equal) 25 mm 45°	No	14.14
	xvii HD-Elbow (Equal) 32 mm 45°	No	24.52
	xviii HD-Elbow (Equal) 40 mm 45°	No	33.00
	xix HD-Elbow (Equal) 50 mm 45°	No	47.15
	xx HD-Elbow (Equal) 63 mm 45°	No	78.26
	xxi HD-Elbow (Equal) 75 mm 45°	No	123.53
	xxii HD-Elbow (Equal) 90 mm 45°	No	252.71
	xxiii HD-Elbow (Equal) 110 mm 45°	No	363.98
5	<b>SUPPLYING, FITTINGS &amp; FIXING OF PVC HD-END CAP (PLAIN) AS PER IS 7834 ( HIGH DENSITY)</b>		
	i HD-End Cap (Plain) 20 mm	No	4.71
	ii HD-End Cap (Plain) 25 mm	No	5.66
	iii HD-End Cap (Plain) 32 mm	No	10.37
	iv HD-End Cap (Plain) 40 mm	No	19.80
	v HD-End Cap (Plain) 50 mm	No	26.40
	vi HD-End Cap (Plain) 63 mm	No	35.83
	vii HD-End Cap (Plain) 75 mm	No	65.06
	viii HD-End Cap (Plain) 90 mm	No	105.61
	ix HD-End Cap (Plain) 110 mm	No	127.30
	x HD-End Cap (Plain) 125 mm	No	222.54
	xi HD-End Cap (Plain) 140 mm	No	314.00
	xii HD-End Cap (Plain) 160 mm	No	455.44
	xiii HD-End Cap (Plain) 200 mm	No	759.07
6	<b>SUPPLYING, FITTINGS &amp; FIXING OF PVC HD-THREADED END CAP AS PER IS 7834 ( HIGH DENSITY)</b>		
	i HD-Threaded End Cap 1.25" (40 mm)	No	24.52
	ii HD-Threaded End Cap 1.5" (50 mm)	No	32.06
	iii HD-Threaded End Cap 2" (63 mm)	No	39.60
	iv HD-Threaded End Cap 2.5" (75 mm)	No	57.52



It. No.	Description of item	Unit	Basic Price in Rs
v	HD-Threaded End Cap 3" (90 mm)	No	79.21
vi	HD-Threaded End Cap 4" (110 mm)	No	113.15
7	<b>SUPPLYING, FITTINGS &amp; FIXING OF PVC HD-TAIL PIECE AS PER IS 7834 ( HIGH DENSITY)</b>		
i	HD-Tail Piece 50 mm	No	23.57
ii	HD-Tail Piece 63 mm	No	40.55
iii	HD-Tail Piece 75 mm	No	49.03
iv	HD-Tail Piece 90 mm	No	81.09
v	HD-Tail Piece 110 mm	No	127.30
8	<b>SUPPLYING, FITTINGS &amp; FIXING OF PVC HD FEMALE THREADED ADOPTOR AS PER IS 7834 ( HIGH DENSITY)</b>		
i	HD-FemaleThreaded Adapter 0.5"(20 mm)	No	9.43
ii	HD-FemaleThreaded Adapter 0.75"(25 mm)	No	12.26
iii	HD-FemaleThreaded Adapter 1" (32 mm)	No	13.20
iv	HD-FemaleThreaded Adapter 1.25 (40 mm)	No	24.52
v	HD-FemaleThreaded Adapter 1.5" (50 mm)	No	46.20
vi	HD-FemaleThreaded Adapter 2" (63 mm)	No	66.95
vii	HD-FemaleThreaded Adapter 2.5" (75 mm)	No	84.87
viii	HD-FemaleThreaded Adapter 3" (90 mm)	No	125.41
ix	HD-FemaleThreaded Adapter 4" (110 mm)	No	232.91
9	<b>SUPPLYING, FITTINGS &amp; FIXING OF PVC HD-FEMALE THREADED COUPLER AS PER IS 7834 ( HIGH DENSITY)</b>		
i	HD-FemaleThreaded Coupler 1/2" (20 mm)	No	12.26
ii	HD-FemaleThreaded Coupler 3/4" (25 mm)	No	15.09
iii	HD-FemaleThreaded Coupler 1" (32 mm)	No	21.69
iv	HD-FemaleThreaded Coupler 1.25" (40 mm)	No	29.23
v	HD-FemaleThreaded Coupler 1.5" (50 mm)	No	50.92
vi	HD-FemaleThreaded Coupler 2.0" (63 mm)	No	90.52
vii	Female Thr Coupler 2.5" (75 mm)	No	121.64
viii	Female Thr Coupler 3.0" (90 mm)	No	212.16
ix	Female Thr Coupler 4.0" (110 mm)	No	293.26
10	<b>SUPPLYING, FITTINGS &amp; FIXING OF PVC HD- REDUCING TEE AS PER IS 7834 ( HIGH DENSITY)</b>		
i	HD-Reducing Tee 63 x 32 x 63 mm	No	119.75
ii	HD-Reducing Tee 63 x 40 x 63 mm	No	119.75
iii	HD-Reducing Tee 63 x 50 x 63 mm	No	121.64
iv	HD-Reducing Tee 75 x 32 x 75 mm	No	181.99
v	HD-Reducing Tee 75 x 40 x 75 mm	No	181.99
vi	HD-Reducing Tee 75 x 50 x 75 mm	No	192.36
vii	HD-Reducing Tee 75 x 63 x 75 mm	No	201.79
viii	HD-Reducing Tee 90 x 32 x 90 mm	No	314.00
ix	HD-Reducing Tee 90 x 40 x 90 mm	No	314.00
x	HD-Reducing Tee 90 x 50 x 90 mm	No	323.43
xi	HD-Reducing Tee 90 x 63 x 90 mm	No	333.80
xii	HD-Reducing Tee 90 x 75 x 90 mm	No	344.18
xiii	HD-Reducing Tee 110 x 50 x 110 mm	No	414.90
xiv	HD-Reducing Tee 110 x 63 x 110 mm	No	425.27
xv	HD-Reducing Tee 110 x 75 x 110 mm	No	434.70
xvi	HD-Reducing Tee 110 x 90 x 110 mm	No	455.44
xvii	HD-Reducing Tee 140 x 63 x 140 mm	No	566.71
xviii	HD-Reducing Tee 140 x 75 x 140 mm	No	566.71
xix	HD-Reducing Tee 140 x 90 x 140 mm	No	596.89

It. No.	Description of item	Unit	Basic Price in Rs
xx	HD-Reducing Tee 140 x 110 x 140 mm	No	616.69
xxi	HD-Reducing Tee 160 x 63 x 160 mm	No	789.25
xxii	HD-Reducing Tee 160 x 75 x 160 mm	No	789.25
xxiii	HD-Reducing Tee 160 x 90 x 160 mm	No	809.05
xxiv	HD-Reducing Tee 160 x 110 x 160 mm	No	829.80
xxv	HD-Reducing Tee 160 x 140 x 160 mm	No	870.34
xxvi	HD-Reducing Tee 180 x 63 x 180 mm	No	1375.76
xxvii	HD-Reducing Tee 180 x 75 x 180 mm	No	1386.14
xxviii	HD-Reducing Tee 180 x 90 x 180 mm	No	1395.57
xxix	HD-Reducing Tee 180 x 110 x 180 mm	No	1405.94
xxx	HD-Reducing Tee 180 x 140 x 180 mm	No	1436.11
xxxi	HD-Reducing Tee 180 x 160 x 180 mm	No	1506.83
xxxii	HD-Reducing Tee 200 x 32 x 200 mm	No	1917.96
xxxiii	HD-Reducing Tee 200 x 50 x 200 mm	No	1917.96
xxxiv	HD-Reducing Tee 200 x 63 x 200 mm	No	1917.96
xxxv	HD-Reducing Tee 200 x 90 x 200 mm	No	1917.96
xxxvi	HD-Reducing Tee 200 x 110 x 200 mm	No	1942.48
xxxvii	HD-Reducing Tee 200X140X200 mm	No	1951.91
xxxviii	HD-Reducing Tee 200X160X200 mm	No	1972.65
xxxix	HD-Reducing Tee 200X180X200 mm	No	2013.20
11	<b>SUPPLYING, FITTINGS &amp; FIXING OF PVC HD-TEE (EQUAL) AS PER IS 7834 ( HIGH DENSITY)</b>		
i	HD-Tee (Equal) 20 mm	No	12.26
ii	HD-Tee (Equal) 25 mm	No	14.14
iii	HD-Tee (Equal) 32 mm	No	22.63
iv	HD-Tee (Equal) 40 mm	No	36.78
v	HD-Tee (Equal) 50 mm	No	65.06
vi	HD-Tee (Equal) 63 mm	No	121.64
vii	HD-Tee (Equal) 75 mm	No	192.36
viii	HD-Tee (Equal) 90 mm	No	314.00
ix	HD-Tee (Equal) 110 mm	No	394.15
x	HD-Tee (Equal) 125 mm	No	798.68
xi	HD-Tee (Equal) 140 mm	No	657.24
xii	HD-Tee (Equal) 160 mm	No	920.32
xiii	HD-Tee (Equal) 180 mm	No	1234.32
xiv	HD-Tee (Equal) 200 mm	No	1820.84
12	<b>SUPPLYING, FITTINGS &amp; FIXING OF PVC HD-MALE THREADED ADAPTER AS PER IS 7834 ( HIGH DENSITY)</b>		
i	HD-Male-Threaded Adapter 0.5" (20 mm)	No	6.60
ii	HD-Male-Threaded Adapter 0.75"(25 mm)	No	7.54
iii	HD-Male-Threaded Adapter 1" (32 mm)	No	11.32
iv	HD-Male-Threaded Adapter 1.25"(40 mm)	No	20.74
v	HD-Male-Threaded Adapter 1.50" (50 mm)	No	31.12
vi	HD-Male-Threaded Adapter 2" (63 mm)	No	52.81
vii	HD-Male-Threaded Adapter 2.50" (75 mm)	No	69.78
viii	HD-Male-Threaded Adapter 3" (90 mm)	No	107.50
ix	HD-Male-Threaded Adapter 4" (110 mm)	No	171.62
13	<b>SUPPLYING, FITTINGS &amp; FIXING OF PVC HD-MALE MOULDED FLANGE AS PER IS 7834 ( HIGH DENSITY)</b>		
i	HD-PVC Molded Flange 50 mm	No	100.90
ii	HD-PVC Molded Flange 63 mm	No	111.27
iii	HD-PVC Molded Flange 75 mm	No	131.07

KM

It. No.	Description of item	Unit	Basic Price in Rs
iv	HD-PVC Molded Flange 90 mm	No	151.81
v	HD-PVC Molded Flange 110 mm	No	181.99
vi	HD-PVC Molded Flange 125 mm	No	212.16
vii	HD-PVC Molded Flange 160 mm	No	242.34
14	<b>SUPPLYING, FITTINGS &amp; FIXING OF PVC HD REDUCING BUSH AS PER IS 7834 ( HIGH DENSITY)</b>		
i	HD-Reducing Bush 25x20 mm	No	6.60
ii	HD-Reducing Bush 32x20 mm	No	10.37
iii	HD-Reducing Bush 32x25 mm	No	10.37
iv	HD-Reducing Bush 40x20 mm	No	9.43
v	HD-Reducing Bush 40x25 mm	No	9.43
vi	HD-Reducing Bush 40x32 mm	No	11.32
vii	HD-Reducing Bush 50x20 mm	No	20.74
viii	HD-Reducing Bush 50x32 mm	No	21.69
ix	HD-Reducing Bush 50x40 mm	No	16.03
x	HD-Reducing Bush 63x32 mm	No	30.17
xi	HD-Reducing Bush 63x40 mm	No	28.29
xii	HD-Reducing Bush 63x50 mm	No	26.40
xiii	HD-Reducing Bush 75x40 mm	No	37.72
xiv	HD-Reducing Bush 75x50 mm	No	39.60
xv	HD-Reducing Bush 75x63 mm	No	39.60
xvi	HD-Reducing Bush 90x40 mm	No	56.58
xvii	HD-Reducing Bush 90x50 mm	No	58.46
xviii	HD-Reducing Bush 90x63 mm	No	68.84
xix	HD-Reducing Bush 90x75 mm	No	60.35
xx	HD-Reducing Bush 110x63 mm	No	91.47
xxi	HD-Reducing Bush 110x75 mm	No	91.47
xxii	HD-Reducing Bush 110x90 mm	No	91.47
xxiii	HD-Reducing Bush 125x110 mm	No	111.27
xxiv	HD-Reducing Bush 140x125 mm	No	141.44
xxv	HD-Reducing Bush 200x160 mm	No	425.27
15	<b>SUPPLYING, FITTINGS &amp; FIXING OF PVC HD REDUCING ELBOW AS PER IS 7834 ( HIGH DENSITY)</b>		
i	PVC HD-Reducing Elbow 50X40 MM	No	52.81
ii	PVC HD-Reducing Elbow 63X50 MM	No	84.87
16	<b>SUPPLYING, FITTINGS &amp; FIXING OF PVC HD REDUCING FEMALE THREADED ADAPTER AS PER IS :7834</b>		
i	HD-Reducing FemaleThreaded Adapter 25 x 1/2"	No	18.86
ii	HD-Reducing FemaleThreaded Adapter 63 x 1-1/2"	No	63.18
iii	HD-Reducing FemaleThreaded Adapter 75 x 1-1/2"	No	76.38
iv	HD-Reducing FemaleThreaded Adapter 75 x 2"	No	86.75
v	HD-Reducing FemaleThreaded Adapter 90 x 2-1/2"	No	121.64
17	<b>SUPPLYING, FITTINGS &amp; FIXING OF PVC HD-REDUCER AS PER IS 7834 ( HIGH DENSITY)</b>		
i	HD-Reducer 25 x 20 mm	No	8.49
ii	HD-Reducer 32 x 20 mm	No	9.43
iii	HD-Reducer 32 x 25 mm	No	11.32
iv	HD-Reducer 40 x 20 mm	No	16.03
v	HD-Reducer 40 x 25 mm	No	16.97
vi	HD-Reducer 40 x 32 mm	No	16.03
vii	HD-Reducer 50 x 25 mm	No	28.29
viii	HD-Reducer 50 x 32 mm	No	29.23

KM

It. No.	Description of item	Unit	Basic Price in Rs
ix	HD-Reducer 50 x 40 mm	No	31.12
x	HD-Reducer 63 x 32 mm	No	40.55
xi	HD-Reducer 63 x 40 mm	No	41.49
xii	HD-Reducer 63 x 50 mm	No	49.98
xiii	HD-Reducer 75 x 40 mm	No	81.09
xiv	HD-Reducer 75 x 50 mm	No	85.81
xv	HD-Reducer 75 x 63 mm	No	88.64
xvi	HD-Reducer 90 x 40 mm	No	89.58
xvii	HD-Reducer 90 x 50 mm	No	92.41
xviii	HD-Reducer 90 x 63 mm	No	100.90
xix	HD-Reducer 90 x 75 mm	No	106.55
xx	HD-Reducer 110 x 63 mm	No	165.96
xxi	HD-Reducer 110 x 75 mm	No	176.33
xxii	HD-Reducer 110 x 90 mm	No	181.99
18	<b>SUPPLYING, FITTINGS &amp; FIXING OF HD-PVC SERVICE SADDLE HEAVY DUTY AS PER IS 7834 ( HIGH DENSITY)</b>		
i	HD-PVC Service Saddle 32 mm x 1/2"	No	51.86
ii	HD-PVC Service Saddle 32 mm x 3/4"	No	51.86
iii	HD-PVC Service Saddle 40 mm x 1/2"	No	78.26
iv	HD-PVC Service Saddle 40 mm x 3/4"	No	78.26
v	HD-PVC Service Saddle 40 mm x 1"	No	81.09
vi	HD-PVC Service Saddle 50 mm x 1/2"	No	84.87
vii	HD-PVC Service Saddle 50 mm x 3/4"	No	84.87
viii	HD-PVC Service Saddle 50 mm x 1"	No	84.87
ix	HD-PVC Service Saddle 63 mm x 1/2"	No	111.27
x	HD-PVC Service Saddle 63 mm x 3/4"	No	111.27
xi	HD-PVC Service Saddle 63 mm x 1"	No	114.10
xii	HD-PVC Service Saddle 75 mm x 1/2"	No	139.56
xiii	HD-PVC Service Saddle 75 mm x 3/4"	No	139.56
xiv	HD-PVC Service Saddle 75 mm x 1"	No	139.56
xv	HD-PVC Service Saddle 90 mm x 1/2"	No	162.19
xvi	HD-PVC Service Saddle 90 mm x 3/4"	No	162.19
xvii	HD-PVC Service Saddle 90 mm x 1"	No	162.19
xviii	HD-PVC Service Saddle 110 mm x 1/2"	No	178.22
xix	HD-PVC Service Saddle 110 mm x 3/4"	No	178.22
xx	HD-PVC Service Saddle 110 mm x 1"	No	178.22
19	<b>SUPPLYING, FITTINGS &amp; FIXING OF HD PVC PLAIN SERVICE SADDLE AS PER IS 7834 ( HIGH DENSITY)</b>		
i	HD-PVC Service Saddle 75X25 MM	No	78.26
ii	HD-PVC Service Saddle 75X32 MM	No	119.75
iii	HD-PVC Service Saddle 90X25 MM	No	84.87
iv	HD-PVC Service Saddle 90X32 MM	No	115.04
20	<b>SUPPLYING, FITTINGS &amp; FIXING OF HD- PVC TWO WAY SERVICE SADDLE HEAVY DUTY AS PER IS 7834.</b>		
i	HD PVC -Two Way Service Saddle 32 x 1/2" x 1/2"	No	62.23
ii	HD PVC -Two Way Service Saddle 32 x 3/4 x 3/4"	No	62.23
iii	HD PVC -Two Way Service Saddle 40 x 1/2" x 1/2"	No	99.01
iv	HD PVC -Two Way Service Saddle 40 x 3/4" x 3/4"	No	95.24
v	HD PVC -Two Way Service Saddle 50 x 1/2" x 1/2"	No	111.27

It. No.	Description of item	Unit	Basic Price in Rs
<b>Drip and Accessories</b>			
1	<b>Supplying , fittings &amp; Fixing of Drip Lateral Class - 2 (LLDPE) as per IS:12786</b>		
	i Tube OD 12 mm Cl2	Metre	8.49
	ii Tube OD 16mm Cl2	Metre	14.14
	iii Tube OD 20mm Cl2	Metre	18.86
	iv Tube OD 25mm Cl2	Metre	33.00
	v Tube OD 32mm Cl2	Metre	49.98
2	<b>Supplying , fittings &amp; Fixing of Micro tube and Accessories as per IS:14482</b>		
	i Micro tube od 6 mm, 1.0 mm W.t.	Metre	4.71
	ii Micro tube od 8 mm, 1.0 mm W.t	Metre	6.60
3	<b>Supplying , fittings &amp; Fixing of Emitters/Drippers as per IS:13487</b>		
	i Dripper 2, 4, 8, 14 lph	No	2.83
	ii Self Cleaning PC Dripper 2.2, 4.2, 8.2 lph	No	3.77
	iii Self Cleaning PC Dripper 2, 3, 4, 8, 12 lph antileak	No	5.66
4	<b>Supplying , fittings &amp; Fixing of Micro Sprayers as per IS 14605</b>		
	i Mini spray Jet 180/270/360 deg 20/40 lph	No	3.77
	ii MI S-jet 180/270/360 deg 20/40 I Ass 1M w/o riser	No	6.60
	iii MI S-jet180/ 270/360 deg 20/40 I Ass 1MSSJ	No	15.09
5	<b>Supplying , fittings &amp; Fixing of Non Pressure Companseting (NPC) Emitting Pipe (LLDPE) as per IS 13488</b>		
5.1	<b>12 mm (OD), 0.8 to 4.0 lph, Class 2 IS 13488</b>		
	i 12mm 20cm cl2 npc	Metre	10.37
	ii 12mm 30cm cl2 npc	Metre	9.43
	iii 12mm 40cm cl2 npc	Metre	9.43
	iv 12mm 50cm cl2 npc	Metre	8.49
	v 12mm 60cm cl2 npc	Metre	8.49
	vi 12mm 90cm cl2 npc	Metre	7.54
5.2	<b>16 mm (OD), 0.8 to 4.0 lph, Class 2 IS 13488</b>		
	i 16mm 20cm cl2 npc	Metre	16.03
	ii 16mm 30cm cl2 npc	Metre	13.20
	iii 16mm 40cm cl2 npc	Metre	12.26
	iv 16mm 50cm cl2 npc	Metre	11.32
	v 16mm 60cm cl2 npc	Metre	11.32
	vi 16mm 90cm cl2 npc	Metre	11.32
6	<b>Supplying , fittings &amp; Fixing of Pressure Companseting (PC) Emitting Pipe (LLDPE) as per IS 13488</b>		
6.1	<b>PC Inline 12 mm (OD), 1.9 to 4.0 lph, Class 2</b>		
	i 12mm 20cm cl2 npc	Metre	13.20
	ii 12mm 30cm cl2 npc	Metre	11.32
	iii 12mm 40cm cl2 npc	Metre	10.37
	iv 12mm 50cm cl2 npc	Metre	10.37
	v 12mm 60cm cl2 npc	Metre	9.43
	vi 12mm 90cm cl2 npc	Metre	9.43
6.2	<b>PC Inline 16 mm (OD), 1.9 to 4.0 lph, Class 2</b>		
	i 16mm 20cm cl2 npc	Metre	22.63
	ii 16mm 30cm cl2 npc	Metre	18.86
	iii 16mm 40cm cl2 npc	Metre	16.03
	iv 16mm 50cm cl2 npc	Metre	15.09
	v 16mm 60cm cl2 npc	Metre	14.14
	vi 16mm 90cm cl2 npc	Metre	13.20

It. No.	Description of item	Unit	Basic Price in Rs
7	<b>Supplying , fittings &amp; Fixing of Poly Joiners as per IS 8008</b>		
i	Poly Joiner 6 mm (Long)	No	0.94
ii	Poly Joiner 6 mm (Short)	No	0.94
iii	Barbed Poly Joiner 12 mm	No	1.89
iv	Barbed Poly Joiner 16 mm	No	2.83
v	Line Joiner 12 mm	No	2.83
vi	Line Joiner 16 mm	No	2.83
vii	Emitting Pipe Joiner 16X16 OD	No	3.77
viii	Emitting Pipe Joiner 12X12 OD	No	2.83
ix	Lateral HD-End Stop "8" Shape 12 mm	No	1.89
x	Lateral HD-End Stop "8" Shape 16 mm	No	2.83
xi	Grommet 13 mm ID	No	2.83
xii	Grommet 8 mm ID	No	2.83
xiii	Poly Take Off 12 x 4 mm (Rainport)	No	1.89
xiv	Poly Take Off 12 x 8 mm	No	2.83
xv	Poly Take Off 12 x 13 mm	No	2.83
xvi	Poly Take Off 16 x 13 mm	No	2.83
xvii	Poly Take Off 20 x 13 mm	No	3.77
xviii	Poly Grommet Take Off 20 X 8 MM	No	5.66
xix	Poly Grommet Take Off 12 X 13MM	No	4.71
xx	Poly Grommet Take Off 16 X 13 MM	No	4.71
xxi	Poly Grommet Take Off 20 X 13 MM	No	5.66
<b>Mini and Micro Sprinkler and Accessories</b>			
1	<b>Supplying , fitting and fixing of Mini and Micro Sprinkler and Accessories of approved make and quality all complete as per direction of Engineer in Charge.</b>		
i	Mini Sprinkler Black 16 to 110 lph	No	11.32
ii	MPS Adaptor 8 mm for Mini Sprinkler	No	4.71
iii	Stake for mini sprinkler ,8mm	No	10.37
iv	Riser MS Rod 6 mm x 1.0 meter	No	20.74
v	Riser MS Rod 6 mm x 1.2 meter	No	21.69
vi	Riser MS Rod 6 mm x 1.5 meter	No	31.12
vii	Riser MS Rod 8 mm x 1.0 meter	No	50.92
viii	Riser MS Rod 8 mm x 1.2 meter	No	57.52
ix	Riser MS Rod 8 mm x 1.5 meter	No	67.89
x	MI Spr 16 to 110 lph, 1.0M Assmeb. 8mm	No	44.32
xi	MI Spr 16 to 110 lph, 1.0M w/o Assemb. 8mm	No	20.74
2	<b>Supplying , fitting and fixing of Plastic Impact Sprinkler as per IS:12232</b>		
i	1/2" Full Circle Plastic Sprinkler	No	174.45
ii	Nozzle Cap For Sprinkler	No	20.74
iii	1/2" FC PL SPR 2.3X1.8 DU NOZ 1.0M	No	285.71
iv	1/2" FC PL SPR 2.3X1.8 DU NOZ 1.2M	No	296.09
v	1/2" FC PL SPR 2.3X1.8 DU NOZ 1.5M	No	314.00
vi	Nozzle for Sprinkler	No	23.57
vii	1/2" Part Circle Plastic Sprinkler	No	199.91
viii	P.C SPR 3.0 MM 1.0 M ASS	No	313.06
ix	P.C SPR 3.0 MM 1.2 M ASS	No	323.43
x	P.C SPR 3.0 MM 1.5 M ASS	No	341.35

It. No.	Description of item	Unit	Basic Price in Rs
3	<b>Supplying , fitting and fixing of Sprinkler &amp; other components for Green House /Poly House/ Shadenet House Irrigation System of approved make and quality all complete as per direction of Engineer in charge.</b>		
i	Fogger 7-28 lph	No	15.09
ii	Fogger 7-28 lph With LPD Low Pr. - Single Way Assembly	No	57.52
iii	Fogger 7-28 lph With LPD Low Pr. - 4 Way Assembly	No	115.98
iv	Leak Prevention Device(LPD)Low Pr. Barb	No	39.60
v	Fogger 7-28 lph With LPD High Pr. - Single Way Assembly	No	57.52
vi	Fogger 7- 28 lph With LPD High Pr. - 4 Way Assembly	No	115.98
vii	Leak Prevention Device High Pressure Barb	No	39.60
viii	Adaptor for Fogger- 4 Way	No	9.43
ix	Weight for Fogger	No	11.32
x	Modular sprinkler 35 to 300 lph	No	17.92
xi	Inverted Green house sprinkler 70 to 200 lph	No	17.92
xii	Inverted Green house sprinkler assembly 70 to 200 lph	No	82.04
xiii	InvertedGreen house sprinkler assbly,W/O lpd 70 to 200 lph	No	43.38
xiv	Greenhouse sprinkler 43 to 200 lph	No	26.40
xv	Greenhouse sprinkler assembly 43 to 200 lph	No	87.69
xvi	Greenhouse sprinkler 43 to 200 lph with lpd	No	69.78
<b>Portable &amp; Semi Permanent Sprinkler</b>			
1	<b>Supplying , Fittings &amp; Fixing of Quick Connect Pipe (Metal Latch Type),as per IS-14151</b>		
i	HDPE Pipes with Quick Release Coupler(Pipe of Class II; 3.2 kg / cm2 IS:14151 Part I 63 mm diameter & 6m long	No	702.50
ii	HDPE Pipes with Quick ReleaseCoupler (Pipe of Class I; 2.5 kg / cm2 IS:14151 Part I, 75 mm diameter & 6m long	No	819.42
iii	HDPE Pipes with Quick Release Coupler (Pipe of Class I; 2.5 kg / cm2 IS:14151 Part I) 90 mm diameter & 6 m long	No	1098.54
2	<b>Supplying , Fittings &amp; Fixing of Quick Connect Service Saddle (Metal Latch) as per IS 14151</b>		
i	QRC HDPE 63 mm Service Saddle IS:14151Part II	No	479.02
ii	QRC HDPE 75mm Service Saddle IS: 14151 Part II	No	529.94
iii	QRC HDPE 90mm Service Saddle IS: 14151 Part II	No	624.23
3	<b>Supplying , Fittings &amp; Fixing of Quick Connect Tee (Metal Latch)as per IS 14151</b>		
i	QRC HDPE Bend with Coupler 90 degree (63 / 50 mm) IS 14151 Part II	No	298.92
ii	QRC HDPE Bend with Coupler 90 degree (75 mm) IS:14151 Part II	No	392.27
iii	QRC HDPE Bend with Coupler 90 degree (90 mm) IS:14151 Part II	No	579.91
4	<b>Supplying , Fittings &amp; Fixing of Quick Connect Tee (Metal Latch)as per IS 14151</b>		
i	QRC HDPE Tee with Coupler (63mm) IS14151 Part II	No	433.76
ii	QRC HDPE Tee with Coupler (75 mm) IS:14151 Part II	No	562.94
iii	QRC HDPE Tee with Coupler (90 mm) IS:14151 Part II	No	786.42
5	<b>Supplying , Fittings &amp; Fixing of Quick Connect Tee (Metal Latch)as per IS 14151</b>		
i	QRC HDPE End Plug (63mm) IS: 14151 Part II	No	111.27
ii	QRC HDPE End Plug (75mm) IS: 14151 Part II	No	116.93
iii	QRC HDPE End Plug (90mm) IS: 14151 Part II	No	233.85
6	<b>Supplying , Fittings &amp; Fixing of Metal Impact Sprinkler as per IS 12232</b>		
i	QRC HDPE Pump Connecting Nipple 63 mm IS: 14151 Part II	No	434.70
ii	QRC HDPE Pump Connecting Nipple, 75 mm IS:14151 Part II	No	507.31
iii	QRC HDPE Pump Connecting Nipple 90 mm IS: 14151 Part II	No	830.74

It. No.	Description of item	Unit	Basic Price in Rs
7	<b>Supplying , Fittings &amp; Fixing of Metal Impact Sprinkler as per IS 12232</b>		
i	Sprinkler Nozzles Full Circle (1.7 to 2.8 kg / cm <sup>2</sup> ) 12m to 18m Radius of Throw , 1200 LPH to 1800 LPH Discharge IS12232 Part I	No	484.68
ii	Sprinkler Nozzles Part Circle (1.7 to 2.8 kg / cm <sup>2</sup> ) 12m to 18m Radius of Throw , 1200 LPH to 1800 LPH Discharge IS12232 Part I	No	1188.12
8	<b>Supplying , Fittings &amp; Fixing of Quick Connect End Riser of approved make and quality all complete as per direction of Engineer in charge</b>		
i	GI Riser Pipe upto 3/4" diameter x 75 cm long	No	181.99
ii	GI Riser Pipe upto 3/4" diameter x 100 cm long	No	216.88
9	<b>Supplying , Fittings &amp; Fixing of Screen / Disc Filter as per IS:12785-1994</b>		
i	Screen Filter 20 / 25 m <sup>3</sup> /hr, 2"	No	3512.49
ii	Disc Filter 30 m <sup>3</sup> /hr, 2.5"	No	6069.77
iii	Disc Filter 20 / 25 m <sup>3</sup> /hr, 2"	No	5173.02
10	<b>Supplying , Fittings &amp; Fixing of By Pass Assembly of approved make and quality all complete as per direction of Engineer in Charge</b>		
i	By Pass Assembly 2"	No	4714.75
ii	By Pass Assembly 2.5"	No	5657.70
<b>Raingun</b>			
1	<b>Supplying , Fittings &amp; Fixing of HDPE Pipes with Quick Release Coupler as per IS:14151 Part I and Class II; 4 kg / cm<sup>2</sup> )</b>		
i	HDPE Pipes with Quick Release Coupler (Pipe of Class II; 4 kg / cm <sup>2</sup> IS:14151 Part I) 63 mm diameter & 6 m long	No	702.50
ii	HDPE Pipes with Quick Release Coupler (Pipe of Class II; 4 kg /cm <sup>2</sup> IS:14151 Part I,) 75 mm diameter & 6m long	No	964.64
iii	HDPE Pipes with Quick Release Coupler (Pipe of Class II; 4 kg / cm <sup>2</sup> IS:14151 Part I, 90 mm) diameter & 6 m long	No	1355.02
2	<b>Supplying , Fittings &amp; Fixing of Raingun as per IS: 12232 (Part II)</b>		
i	Raingun, having 19 m to 34 m radius of throw, Discharge 10,000 LPH to 32,000 LPH	No	5924.55
3	<b>Supplying , Fittings &amp; Fixing of Tripod Stand as per IS: 12232 (Part II)</b>		
i	Tripod Stand 1.2 mtr with 1.25" X 1 mtr. Riser	No	2213.10
ii	Tripod Stand 1.2 mtr with 1.25" X 1.5 mtr. Riser	No	2478.07
4	<b>Supplying , Fittings &amp; Fixing of Quick Connect Bend (Metal Latch)as per IS 14151</b>		
i	QRC HDPE Bend with Coupler 90 Degree (63 mm) IS: 14151 Part II	No	298.92
ii	QRC HDPE Bend with Coupler 90 Degree (75 mm) IS: 14151 Part II	No	392.27
iii	QRC HDPE Bend with Coupler 90 Degree (90mm) IS: 14151 Part II	No	579.91
5	<b>Supplying , Fittings &amp; Fixing of Quick Connect Pump Connector Female (Metal Latch)as per IS 14151</b>		
i	QRC HDPE Pump Connecting Nipple 63 mm IS: 14151 Part II	No	434.70
ii	QRC HDPE Pump Connecting Nipple 75 mm IS: 14151 Part II	No	507.31
iii	QRC HDPE Pump Connecting Nipple, 90 mm IS : 14151 Part II	No	830.74
6	<b>Supplying , Fittings &amp; Fixing of Quick Connect End Plug (Metal Latch) as per IS 14151</b>		
i	QRC HDPE End Plug (63 mm) IS: 14151 Part II	No	111.27
ii	QRC HDPE End Plug (75 mm) IS: 14151 Part II	No	116.93
iii	QRC HDPE End Plug (90 mm) IS: 14151 Part II	No	233.85
7	<b>Supplying , Fittings &amp; Fixing of Quick Connect Tee (Metal Latch) as per IS 14151</b>		
i	QRC HDPE Tee with Coupler (63 mm) IS 14151 Part II	No	433.76
ii	QRC HDPE Tee with Coupler (75 mm) IS 14151 Part II	No	562.94
iii	QRC HDPE Tee with Coupler (90mm) IS: 14151 Part II	No	786.42



It. No.	Description of item	Unit	Basic Price in Rs
8	<b>Supplying , Fittings &amp; Fixing of Screen / Disc Filter as per IS:12785</b>		
i	Screen Filter 20 / 25 m <sup>3</sup> /hr, 2"	No	3732.20
ii	Disc Filter 30 m <sup>3</sup> /hr, 2.5"	No	6448.84
iii	Disc Filter 20 / 25 m <sup>3</sup> /hr, 2"	No	5496.46
9	<b>Supplying , Fittings &amp; Fixing of By Pass Assembly of approved make and quality all complete as per direction of Engineer in charge</b>		
i	By Pass Assembly 2"	No	4714.75
ii	By Pass Assembly 2.5"	No	5657.70
<b>PVC Water Tank</b>			
1	<b>Supplying, Fitting &amp; Fixing of Water Storage tank of Approved quality with closed top with lid (Black) - Multilayer as per IS: 12701</b>		
i	500 Litre Capacity	No	2900.51
ii	1000 Litre Capacity	No	5761.42
iii	1500 Litre Capacity	No	8809.98
iv	2000Litre Capacity	No	11727.47
v	2500 Litre Capacity	No	14644.01
vi	3000Litre Capacity	No	17575.65
vii	4000Litre Capacity	No	23410.62
viii	5000Litre Capacity	No	33518.10
<b>Rain Port Systems</b>			
<b>Supplying , Fitting &amp; Fixing of Compression Fittings as per IS 8360</b>			
i.	MDPE Pipe 20 mm Outside Diameter (SDR 9)	Metre	34.89
ii.	MDPE Pipe 25 mm Outside Diameter (SDR11)	Metre	43.38
iii.	MDPE Pipe 32 mm Outside Diameter (SDR 11)	Metre	69.78
iv.	COMPRESSION ELBOW 20 MM	No	72.61
v.	COMPRISION ELBOW 25 MM	No	95.24
vi.	COMPRESSION ELBOW 32 MM	No	115.04
vii.	COMPRESSION ELBOW 40 MM	No	197.08
viii.	COMPR ELBOW 1/2" MALEX20MM	No	69.78
ix.	COMPR ELBOW 3/4" MALEX25MM	No	86.75
x.	COMPRESSION ELBOW 1" MALEX32 MM	No	115.98
xi.	Elbow 1/4" Metallic Female X 20 mm Compression	No	166.90
xii.	Elbow 1/2" Female X 20 mm Compression	No	79.21
xiii.	Elbow 3/4" Female X 25 mm Compression	No	122.58
xiv.	Elbow 1" Female X32 mm Compression	No	185.76
xv.	COMPR ADOPTER 1/2" MALEX20MM	No	53.75
xvi.	COMPR ADOPTER 3/4" MALEX20MM	No	57.52
xvii.	COMPR ADOPTER 3/4" MALEX25MM	No	58.46
xviii.	COMPR ADOPTER 1" MALE X32MM	No	66.01
xix.	COMPR ADOPTER 1 25" MALEX40MM	No	108.44
xx.	COMPR ADOPTER 1/2" FEMALEX20MM	No	53.75
xxi.	COMPR ADOPTER 3/4" FEMALEX25MM	No	64.12
xxii.	COMPR ADOPTER 1" FEMALEX32MM	No	73.55
xxiii.	COMPRESSION JOINER 20 MM	No	62.23
xxiv.	COMPRESSION JOINER 25 MM	No	78.26
xxv.	COMPRESSION JOINER 32 MM	No	85.81
xxvi.	COMPRESSION JOINER 40 MM	No	185.76
xxvii.	SING UNION VALVE 20MM COMPX1/2"FM	No	154.64
xxviii.	SING UNION VALVE 25MM COMPX3/4"FM	No	182.93
xxix.	SING UNION VALVE 32MM COMPX1"FM	No	253.65

It. No.	Description of item	Unit	Basic Price in Rs
xxx.	SINGLE UNION VALVE 1/2" M/FM	No	147.10
xxxi.	SINGLE UNION VALVE 3/4" M/FM	No	168.79
xxxii.	SINGLE UNION VALVE 1" M/FM	No	217.82
xxxiii.	SINGLE UNION VALVE 1/2" FEMALE	No	140.50
xxxiv.	SINGLE UNION VALVE 3/4" FEMALE	No	161.24
xxxv.	SINGLE UNION VALVE 1" FEMALE	No	211.22
xxxvi.	COMPRESSION END CAP 20 MM	No	57.52
xxxvii.	COMPRESSION END CAP 25 MM	No	64.12
xxxviii.	COMPRESSION END CAP 32 MM	No	80.15
xxxix.	COMPRESSION END CAP 40 MM	No	131.07
XL	COMPRESSION TEE 20 MM	No	95.24
XLI	COMPRESSION TEE 25 MM	No	120.70
XLII	COMPRESSION TEE 32 MM	No	129.18
XLIII	COMPRESSION TEE 40 MM	No	277.23
XLIV	COMPRESSION TEE 1/2" MALEX20 MM	No	110.33
XLV	COMPRESSION TEE 3/4" MALEX25 MM	No	137.67
XLVI	COMPRESSION TEE 1" MALE X 32 MM	No	147.10
XLVII	THREADED TEE 1/2" MALE	No	114.10
XLVIII	THREADED TEE 3/4" MALE	No	139.56
XLIX	THREADED TEE 1" MALE	No	149.93

# SECTION OF TYPICAL H.D. TUBEWELL

NOT TO SCALE

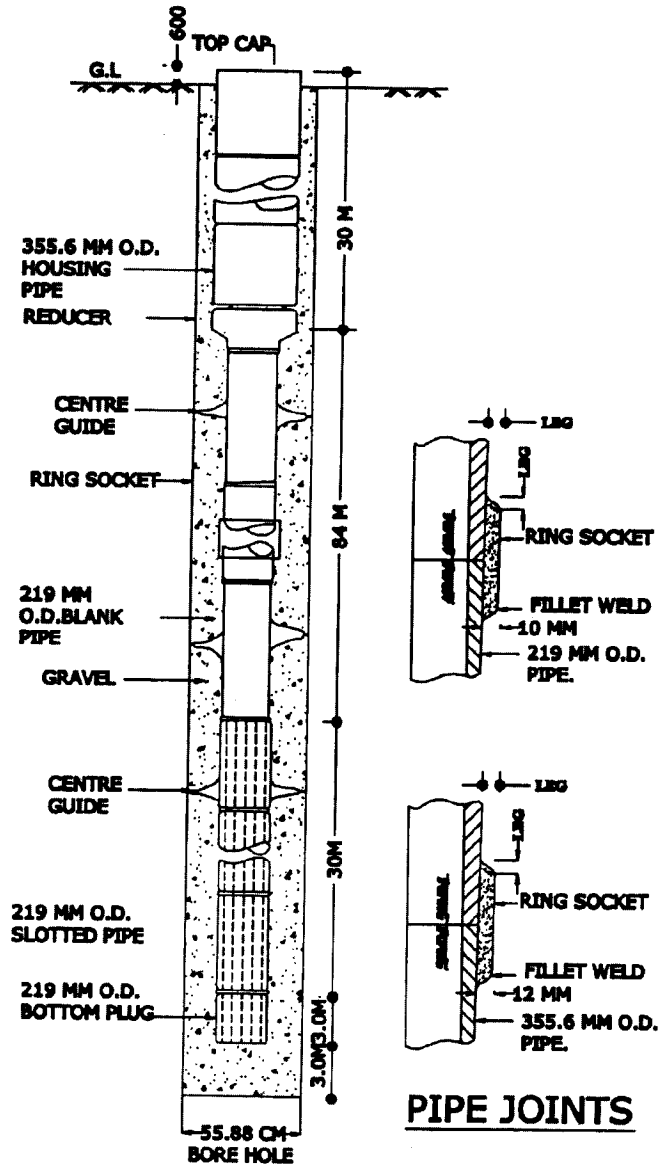

SKETCH - 1

# SECTION OF TYPICAL M.D. TUBEWELL

NOT TO SCALE

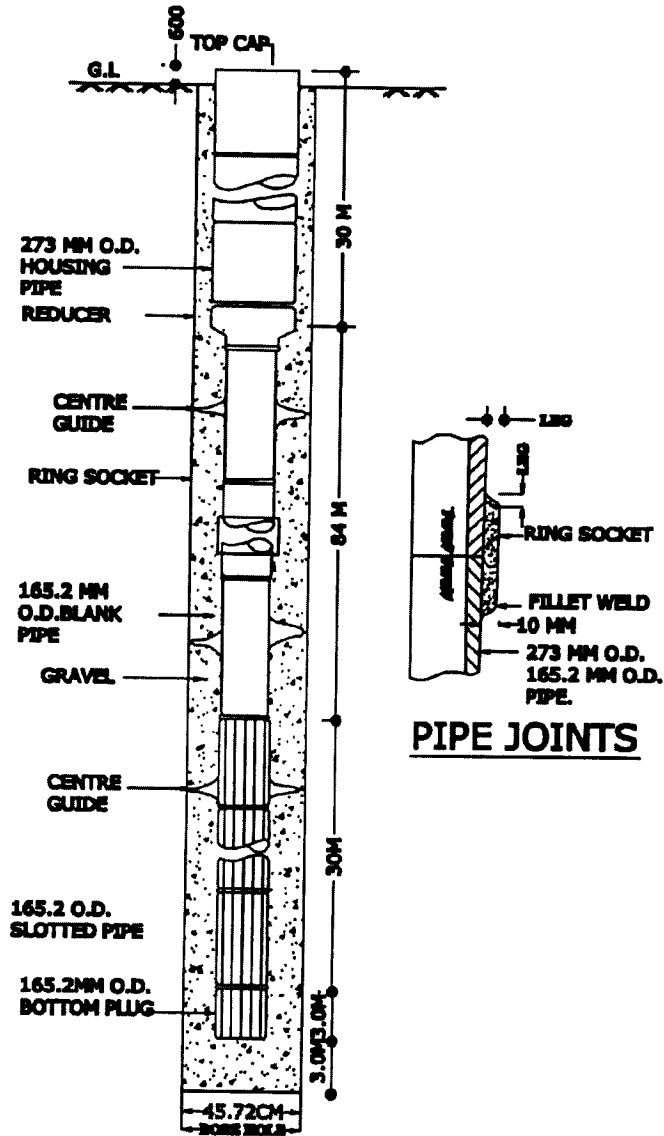

SKETCH-2

**SLOTTED PIPE OF 219mm O.D.&  
165.2 mm OD ERW PIPE**

SKETCH-3

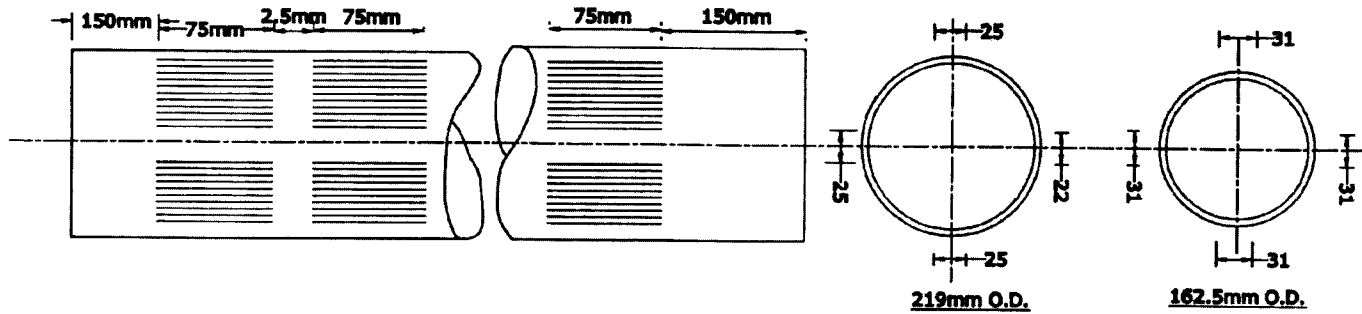

**219mm O.D.  
DETAILS OF SLOTTED PIPE**

SL.NO	DESCRIPTIONS	RESULTS
1.	OUTSIDE OF PIPES	219mm
2.	NO OF SLOTS PER ROW	96
3.	SIZE OF EACH SLOT OPENING FROM OUTSIDE	75 X 1.6
4.	TOTAL NO OF SLOTS PER METRE	960

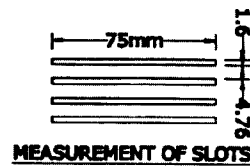

**162.5mm O.D. NOMINAL BORE  
DETAILS OF SLOTTED PIPE**

SL.NO	DESCRIPTIONS	RESULTS
1.	NORMAL DIA OF PIPE	165.2mm
2.	NO OF SLOTS PER ROW	64
3.	SIZE OF EACH SLOT OPENING FROM OUTSIDE	75X1.6
4.	TOTAL NO OF SLOTS PER METRE	640

**TOLERANCE OF 5% IN ALL DIMENSIONS**

# MODEL RIVER LIFT IRRIGATION SCHEME WITH PIPELINE

**COMMAND AREA=72 ha**  
**CONTOUR INTERVAL=1'**

**LEGENDS:-**

- WATER POINT :- ○
- PRIMARY DISTRIBUTION CHAMBER :- □
- SECONDARY DISTRIBUTION CHAMBER :- □
- LEAD LINE :- ———
- CLOSED LOOP/BRANCHING :- ———
- OUTLET VALVE :- ○
- COMMAND AREA BOUNDARY :- - - -

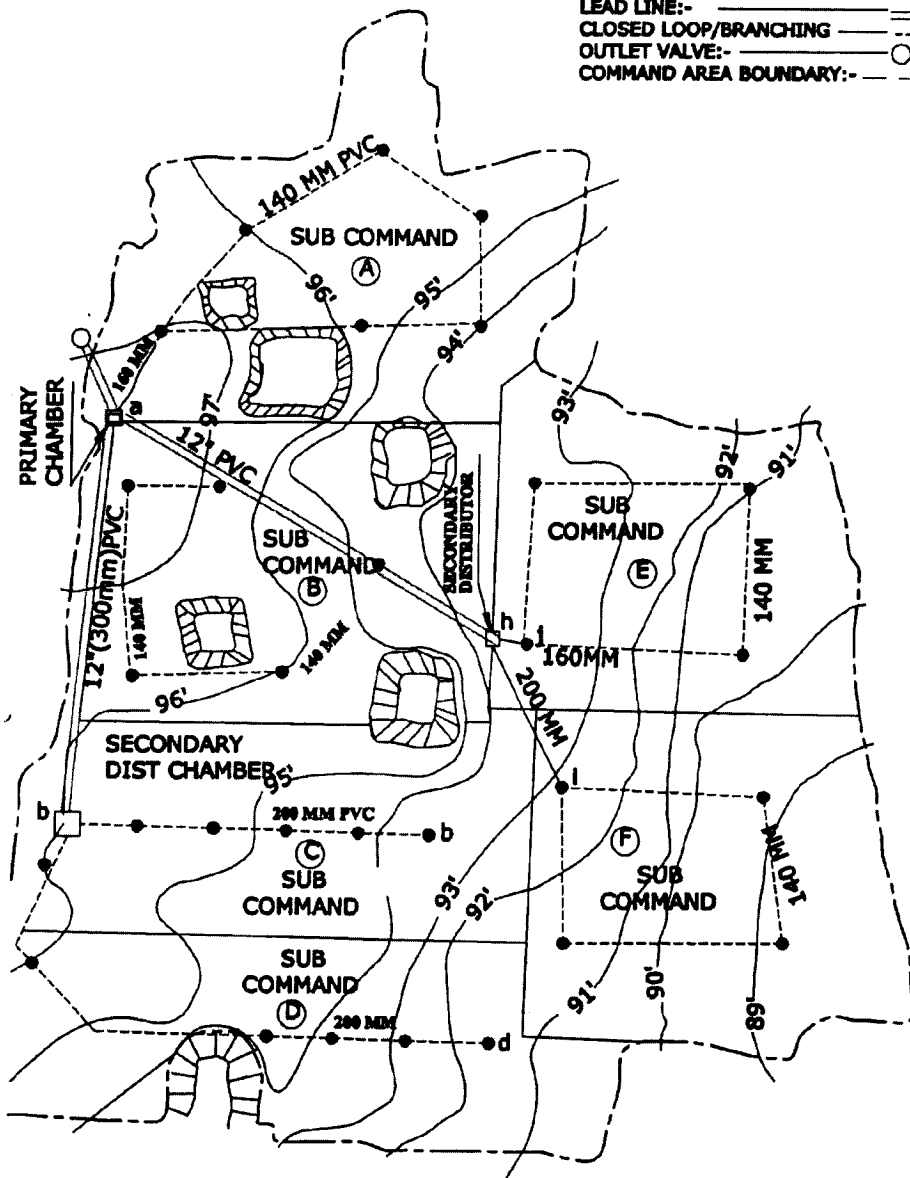

SKETCH-4

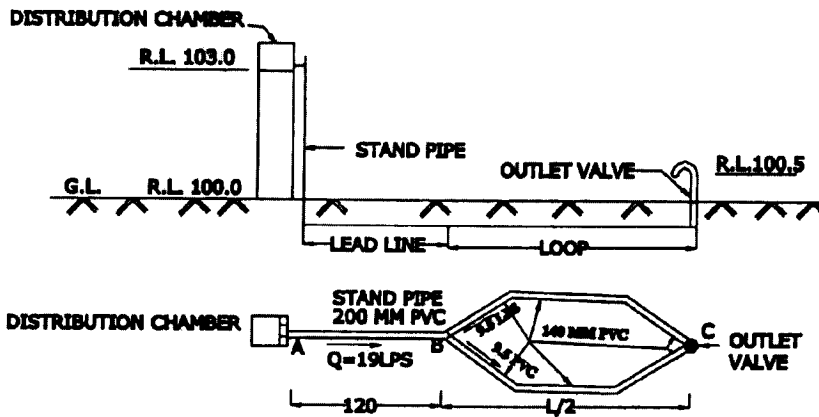

### P.V.C. PIPELINE CLOSED LOOP

NOT TO SCALE

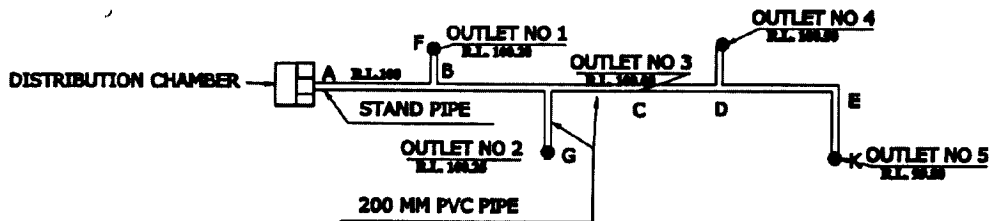

### P.V.C. PIPELINE BRANCHING SYSTEM

NOT TO SCALE

SKETCH - 5

# MODEL H.D.T.W. IRRIGATION COMMAND & PIPELINE (P.V.C.)

COMMAND AREA-39HA  
 CONTOUR INTERVALS-0.5 FT

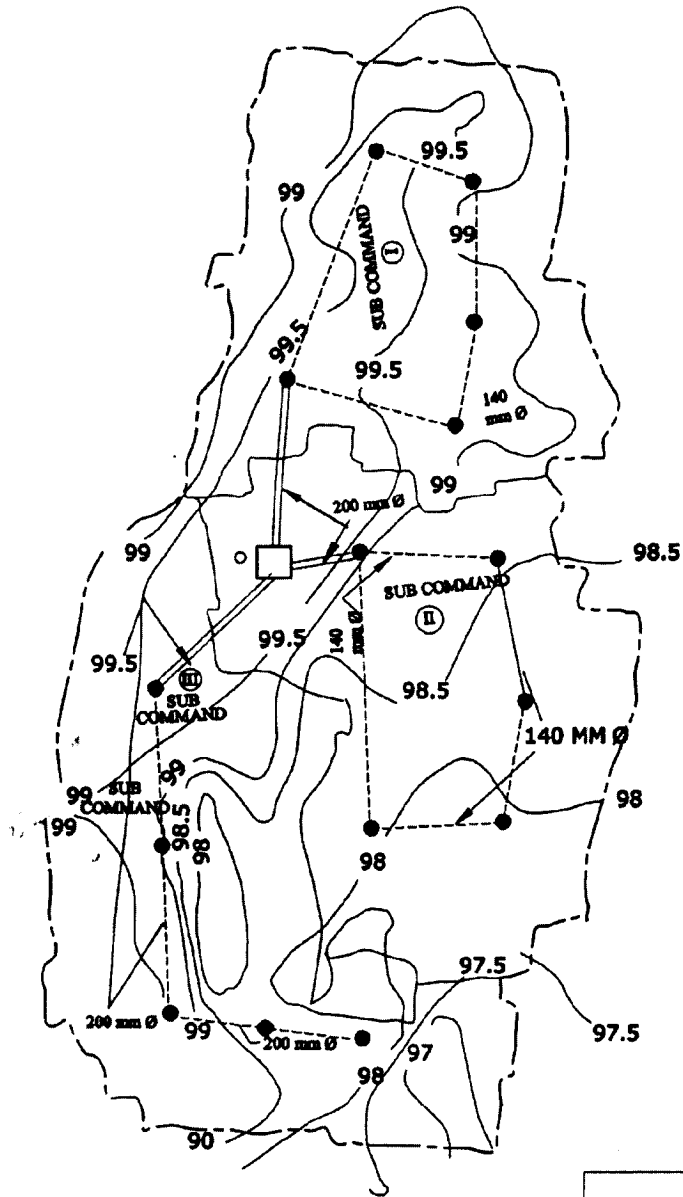

SKETCH-6

## LEGENDS

1	LEAD LINE	=====
2	CLOSED LOOP/BRANCHING	-----
3	OUTLET VALVE/SPOUT (CHAMBER)	●
4	COMMAND AREA BOUNDARY	- - - - -
5	DISTRIBUTION CHAMBER	□
6	WATER POINT	○